

C-197
P/N 157413
REVISION H
11/2007

RBC1-50 WITH PROTOCOL *PLUS*[™] INSTRUCTION MANUAL

RBC1-50 Despatch Ovens are bench ovens designed for operation to 260°C (500°F) with forced convection airflow.

| Model | Volts | Heater watts | Amps | HZ | Phase |
|---------|-------|--------------|------|----|-------|
| RBC1-50 | 208 | 3,000 | 23 | 60 | 1 |
| | 220 | 3,360 | 24 | 50 | 1 |
| | 240 | 4,000 | 24 | 60 | 1 |

Prepared by:
Despatch Industries
8860 207th St. West
Lakeville, MN 55044
Customer Service 800-473-7373

Notice

Users of this equipment must comply with operating procedures and training of operation personnel as required by the Occupational Safety and Health Act (OSHA) of 1970, Section 6 and relevant safety standards, as well as other safety rules and regulations of state and local governments. Refer to the relevant safety standards in OSHA and National Fire Protection Association (NFPA), section 86 of 1990.

Caution

Setup and maintenance of the equipment should be performed by qualified personnel who are experienced in handling all facets of this type of system. Improper setup and operation of this equipment could cause an explosion that may result in equipment damage, personal injury or possible death.

Dear Customer,

Thank you for choosing Despatch Industries. We appreciate the opportunity to work with you and to meet your heat processing needs. We believe that you have selected the finest equipment available in the heat processing industry.

At Despatch, our service does not end after the purchase and delivery of our equipment. For this reason we have created the Service Products Division within Despatch. The Service Products Division features our Response Center for customer service. The Response Center will direct and track your service call to ensure satisfaction.

Whenever you need service or replacement parts, contact the Response Center at 1-800-473-7373: FAX 612-781-5353.

Thank you for choosing Despatch.

Sincerely,
Despatch Industries



Standard Products Product Warranty

Products Covered by this Warranty

This warranty (the "warranty") applies to the following Despatch products: LEB, LBB, LAC, LCC, LCD, LLD, RAD, RFD, LND, RTFO, TAD, TFD, PR, PN, PW, PTC and the following Ransco products: RTH, RTS, 900 Series.

Parts and Materials

Despatch warrants all parts and materials to be free from defects in material and workmanship for a period of:

1. Five (5) years from date of shipment for laboratory oven electric heaters.
2. Three (3) years from the date of shipment for Protocol Plus and DES 2000 temperature controllers; and
3. One (1) year from the date of shipment, or 2,000 hours of operation, whichever occurs first, for all other components of products covered by this Warranty.

During the applicable Warranty period, Despatch will repair or replace, at Despatch's option, parts and materials covered by this Warranty.

Labor

During the first 90 days of the Warranty period, Despatch will pay labor costs incurred to remove defective parts and materials, and to reinstall repaired or replacement parts or materials; provided, however, that Despatch's obligation to pay such labor costs shall be subject to the limitation that the removal and/or reinstallation service must be performed by a Despatch-authorized technician from Despatch's worldwide network of factory-trained professionals at a location within the contiguous United States.

Transportation Costs

All transportation costs to transport defective parts or materials to Despatch and to transport repaired or replacement parts or materials to Customer shall be the responsibility of Despatch.

Terms and Conditions

This Warranty shall be deemed valid and binding upon Despatch if and only if the Customer:

1. Installs, loads, operates, and maintains the covered product supplied hereunder in accordance with the instruction manual provided upon delivery and product labeling affixed to the subject equipment;
2. If applicable, follows the Emergency Procedure set forth in this Warranty; and
3. Contacts Despatch's Helpline at 1-800-473-7373 for assistance in diagnosing and troubleshooting the problem immediately upon discovering any damage or malfunction.

Despatch's reasonable determination as to whether a repair, replacement, or service is covered by this Warranty shall be final and binding.

Exclusions

This Warranty DOES NOT cover,

1. Damage or malfunctions, or expenses incurred in the process of diagnosing and/or repairing damage or malfunctions, resulting from any of the following: operator

THE REPRESENTATION AND WARRANTIES SET FORTH HEREIN ARE EXCLUSIVE AND IN LIEU OF, AND CUSTOMER HEREBY WAIVES AND DISCLAIMS RELIANCE UPON, ALL OTHER REPRESENTATIONS AND WARRANTIES OF EVERY KIND WHATSOEVER WHETHER EXPRESS OR IMPLIED, OR ARISING BY OPERATION OF LAW OR IN EQUITY, OR BY COURSE OF PERFORMANCE OR DEALING OR USAGE OF TRADE, INCLUDING, WITHOUT LIMITATION, ANY IMPLIED WARRANTIES OF MERCHANTABILITY OR OF FITNESS FOR A PARTICULAR PURPOSE.

THIS WARRANTY IS PERSONAL TO THE CUSTOMER AND MAY NOT BE TRANSFERRED OR ASSIGNED. ALL LIMITATIONS HEREUNDER, HOWEVER SHALL BE BINDING ON ALL SUCCESSORS AND ASSIGNS OF CUSTOMER.

error, misuse, abuse, inadequate preventative maintenance, normal wear and tear, service or modifications by other than Despatch authorized technicians, use of the covered product that is inconsistent with the operation manual or labeling, acts of nature (including, without limitation, floods, fire, earthquake, or acts of war or civil emergency), internal or external corrosion, or non-conforming utilities (including, without limitation, electrical, fuel supply, environmental and intake/exhaust installations);

2. Repair or replacement of parts or materials designed and intended to be expendable or consumable; refrigerants, filters, lamps;
3. Routine maintenance; or
4. Labor costs incurred for troubleshooting, diagnostics, or testing (except for testing required to verify that a covered defective part or material has been repaired).

Limitations of Liability

Despatch shall not, in any event, be liable for indirect, special, consequential, incidental, or punitive damages or penalties of any kind, including without limitation loss of revenue, profits or business opportunities resulting from interruption of process or production. In no event shall Despatch be liable for damages in excess of the amounts paid by Customer to Despatch with respect to the applicable product(s). This Warranty does not cover, and Despatch shall not be liable for any losses, costs, damages or expenses resulting from delays in diagnosing or repairing the products, supplying or obtaining replacement parts of materials, strikes, labor stoppages or shortages, fires, accidents, government acts or regulations, or any other causes beyond the control of Despatch.

Non-Compliance By Customer

Despatch reserves the right to suspend and withhold service under this Warranty in the event of non-compliance by the Customer to any terms and conditions of this Warranty or the applicable purchase order or invoice. Further, Despatch shall not be liable for any loss of production, expenses, and inconveniences incurred due to such suspension.

Customer Furnished Equipment Warranty Limitation

This Warranty does not cover diagnosis or repairs of defects in or caused by, lack of performance of, or fitness for purpose of customer-supplied parts or equipment unless specifically noted in the Despatch written order acceptance confirmation.

Performance Commitment

Despatch provides no guarantee of process performance or fitness for purpose, unless specifically noted otherwise in Despatch written order acceptance confirmation. Despatch is providing equipment with design parameters specific only to its equipment.

Procedure Upon Discovery of Defects and Emergencies

In the event Customer becomes aware of any defect in the application products, Customer must immediately: (a) shut off fuel or energy supply (gas and electricity); (b) call for emergency assistance, if needed, and (c) notify Despatch Service.

Service

Worldwide Phone 952-469-8230; Worldwide Fax 952-469-8193; North American Phone 800-473-4373
e-mail service@despatch.com; www.despatch.com

Please see reverse side for other service offerings

Despatch Industries

Advantage Service Assurance Program (ASAP)

CONTACT: DESPATCH SERVICE AGREEMENTS SPECIALIST at 800-473-7373 or 952-469-8230
or e-mail: service@despatch.com

Despatch continues to deliver exceptional products backed by a strong sense of responsibility and drive for long term customer satisfaction. Your partnership with Despatch can offer even higher value through your subscription to one of Despatch's Advantage Service Assurance Program(ASAP).

Warranty

Despatch's exclusive, comprehensive service programs start with the 1 year parts only warranty which is described on the other side of this document. This warranty can be expanded immediately to meet your most stringent service needs. Despatch Service Products Group will be able to answer your service questions and provide a quotation for the immediate expansion of your product warranty. Call 800-473-7373 or 952-469-8230; or e-mail service@despatch.com.

Immediate Service Response

The key to an effective service program is response. Wherever your location, Despatch is only a phone call away. Our U.S. and Canadian customers can reach Despatch at 1-800-473-7373. Worldwide customers can call 1-952-469-8230 or FAX 1-952-469-8193. Our Customer Service Technicians have over 150 years combined experience and access to detailed design and manufacturing documentation specific to your Despatch unit(s). This exacting level of service is a benefit only Despatch can provide and means that you can expect speedy, accurate and the most cost effective response.

Field Service Network

A worldwide network of factory trained Service Professionals is available to support your Despatch equipment. From routine repair to certified instrument calibration, the Despatch service network is positioned to respond to your needs. As a manufacturer of custom equipment, our service programs are customized to meet your specific needs regarding:

1. Service scope
2. Response time
3. Preventive maintenance frequency and content
4. Payment method

Sustained Service Support

At Despatch, long term customer satisfaction means more than just responding quickly and effectively to our customers' service needs. It means offering comprehensive customer support well beyond the scope and duration of our initial warranty. Despatch offers two basic service packages which are customized to each individual customer's need. These service packages are titled Full Service and Preventive Maintenance Plus+ service agreement products. Each is unique in the industry and offer the following benefits:

1. Priority response for minimum production interruption
2. Preventive maintenance for longer product life
3. Discounts on parts and services
4. Various payment plans to ease budgeting and recording expenses
5. Reduce purchase ordering costs

Service

Worldwide Phone 952-469-8230; Worldwide Fax 952-469-8193; North American Phone 800-473-7373
e-mail service@despatch.com; www.despatch.com

PREFACE

This manual is your guide to the Despatch oven. It is organized to give you the information you need quickly and easily.

The INTRODUCTION section provides an overview of the Despatch oven.

The THEORY OF OPERATION section details the function and operation of assemblies and subassemblies on the Despatch oven.

The INSTRUCTIONS section provides directions on unpacking, installing, operating and maintaining the Despatch oven.

The APPENDIX section contains special instructions on air atmosphere and nitrogen atmosphere Burn-In ovens, a Troubleshooting Table, a list of Accessories and a Warranty.

The parts are listed in the corner of the attached prints, the electrical items on the electrical print and the mechanical items on the mechanical prints.

An efficient way to learn about the oven would be to read the manual while working with the corresponding oven control system. This will give you practical hands-on experience with information in the manual and the oven.

Before operating the equipment, be sure you understand all of the technical information contained in this manual. Information skipped, not understood or misunderstood could create the possibility of operating the equipment in an unsafe manner. This can cause damage to the oven or personnel or reduce the efficiency of the equipment.

NOTE:
Read the entire INTRODUCTION and THEORY OF OPERATION before installing the oven.

WARNING:
Failure to heed warnings in this instruction manual and on the oven could result in personal injury, property damage or death.

Revision B (1-02): Updated drawings

Revision C (4-02): Modified per Rev 3.0 Protocol Plus software

Revision D (5-03): Updated drawings and Despatch Industries Product Warranty

Revision E (2-04): Update drawings

Revision F (3-04): Update drawings

Revision G (8-06): Revised Protocol Plus numbers. Updated Despatch address

Revision H (11-07) Updated warranty

TABLE OF CONTENTS

| | |
|--|----|
| PREFACE | i |
| INTRODUCTION..... | 1 |
| Special Features..... | 1 |
| Specifications | 2 |
| Dimensions | 2 |
| Capacities | 2 |
| Temperature | 3 |
| Power..... | 4 |
| Power Requirements..... | 4 |
| THEORY OF OPERATION | 5 |
| Temperature Control..... | 5 |
| Power Switch..... | 6 |
| Air Circulation | 6 |
| Chamber Design..... | 6 |
| Airflow Switch | 6 |
| Alarm | 6 |
| Chamber Door Handle..... | 7 |
| Damper Control | 7 |
| Determining Damper Settings | 7 |
| Full Closed Position..... | 7 |
| Full Open Position | 8 |
| Minimum Opening for Dissipation of Live Load | 8 |
| Other Damper Settings..... | 8 |
| OVEN INSTRUCTIONS | 10 |
| Unpacking and Inspection | 10 |
| Warning Signs Missing | 11 |
| Set-up..... | 12 |
| Power Connection | 13 |
| Operating..... | 14 |
| Loading the Oven..... | 14 |
| Oven Temperature Limit | 14 |
| Product Temperature Limit..... | 15 |
| Operator Training Requirements..... | 15 |
| Pre-Startup Checklist | 16 |
| Startup | 16 |
| PROTOCOL PLUS CONTROLLER | 18 |
| Theory of Control Operation | 18 |
| Operating Modes..... | 20 |
| Setup Mode..... | 20 |
| Fast Start Mode..... | 20 |
| High Limit | 21 |
| Indicators | 21 |
| Displays | 22 |

| | |
|---|-----------|
| Key Functions | 22 |
| Outputs | 23 |
| Relay (Continued) | 24 |
| Communication | 24 |
| Optional Software..... | 24 |
| INSTRUCTIONS | 25 |
| Start-Up | 25 |
| Operation..... | 26 |
| Manual Mode | 26 |
| Timer Mode..... | 27 |
| Profile Mode..... | 28 |
| Auto Start Mode | 28 |
| Setup Mode..... | 29 |
| Instructions for Setup Mode Pages..... | 30 |
| Program Page..... | 30 |
| Profile # | 32 |
| Sample Profile..... | 33 |
| Auto Start Page (optional)..... | 34 |
| PID Page..... | 36 |
| Control Page | 38 |
| Communication Page (optional) | 39 |
| Real Time Clock Page (optional)..... | 39 |
| Relay Outputs Page (optional) | 40 |
| Test Page..... | 41 |
| Zone Calibration Page | 42 |
| Sensor Calibration Page | 44 |
| Enable Page | 46 |
| Digital Inputs (optional) | 47 |
| Error Messages and Alarms | 48 |
| Quick Reference and Default Values..... | 49 |
| Technical Specifications | 56 |
| Maintenance | 57 |
| Checklist | 57 |
| Inspection and Cleaning..... | 58 |
| Vents | 58 |
| Chamber..... | 58 |
| Control Cabinet and Fan | 58 |
| Chamber Door Gasket..... | 59 |
| Recirculation Motor..... | 59 |
| Oven Exterior..... | 59 |
| Oven Chamber Interior | 59 |
| Door Hinges and Latches | 59 |
| Automatic Damper..... | 60 |
| Controls and Indicators..... | 60 |
| Loose Screws, Bolts and Fasteners | 60 |
| Lubrication..... | 60 |

| | |
|---|----|
| Tests | 61 |
| OPTIONAL ACCESSORIES | 62 |
| Door Switch | 62 |
| Recorder | 62 |
| Redundant High-Limit | 62 |
| Disconnect Switch | 63 |
| Stacking Option | 63 |
| Replacement | 64 |
| Parts | 64 |
| Nitrogen and Liquid Nitrogen | 64 |
| Theory of Operation | 64 |
| Operator Training Requirements | 65 |
| Operation | 65 |
| Nitrogen Atmosphere | 67 |
| Purge Rate | 67 |
| Maintain Rate | 68 |
| Troubleshooting | 69 |
| Circuit Board Check | 71 |
| DRAWINGS | 72 |
| APPENDIX: Temperature Scale Conversion and Optional MRC5000 Setup | 75 |
| Temperature Scale Conversion (C/F) | 75 |
| Optional MRC5000 Recorder Setup | 76 |

INTRODUCTION

This instruction manual covers the operation and maintenance of the Despatch RBC1-50 Burn-In oven.

NOTE:
Read the entire
INTRODUCTION and THEORY
OF OPERATION before
installing the oven.

Special Features

The sturdy construction and three-inch insulation top and bottom and four-inches of insulation on the sides of the Despatch RBC1-50 Burn-In ovens contribute to excellent temperature uniformity.

Other special features include the following:

- Unique Despatch design to combine higher fan volume of forced recirculated air with a system of perforated stainless steel walls for the ultimate in temperature uniformity.
- Welded double wall construction and fiberglass insulation to reduce heat loss. Silicone rubber gaskets further minimize heat leakage.
- Rapid response heater.
- Scratch-resistant baked enamel exterior and stainless steel interior for easy cleaning.

Specifications

Dimensions

| Model | Chamber Size in (cm) | | | Capacity feet ³ (liters) | Overall Size in (cm) | | |
|---------|-------------------------|------------|------------|---|-------------------------|------------|---------------|
| | W | D | H | | W | D | H |
| RBC1-50 | 18 (46) | 25 (64) | 18 (46) | 4.7 (133) | 46 (117) | 36 (91) | 31.50 (80) |

Capacities

| | MODEL | |
|---|---------------------------|--------------------------------|
| | RBC1-50 Air Atmosphere | RBC1-50 Nitrogen Atmosphere |
| Maximum Load | 150 Lbs | |
| Fresh Air/ Exhaust Capacity at 125 °C (255 °F) | 51 CFM | N/A |
| Recirculating Fan | 600 CFM 1 HP | |
| Fresh Air Inlet | 2.5" Diameter | N/A |
| Exhaust outlet | 2.18" Diameter | N/A |
| # of Doors | 1 | |
| Approximate Weight | 470 Lbs. (213 KG) | |

Temperature

| | | RBC1-50 Air Atmosphere | RBC1-50 Nitrogen Atmosphere |
|--|--------------|---------------------------|--------------------------------|
| Time to Temperature (approximate minutes with no live load) (1) | 25°C - 80°C | 4 | 4 |
| | 25°C - 125°C | 10 | 10 |
| | 25°C - 150°C | 14 | 14 |
| | 25°C - 260°C | 34 | 30 |
| Recovery Time to 125°C with door open 1 Min. | | >1 Min. | >1 Min. |
| Temperature Uniformity at (2) | 125°C* | <±1°C | <±1°C |
| | 260°C* | ±1°C | ±1°C |
| Operating Temperature Range (Based on 25°C ambient, and dampers fully open) | | 50° - 260°C | 15° - 260°C |
| Control Stability (3) | | ±0.5°C per 5°C Δ | |
| Repeatability | | ±0.5°C | |
| Cooldown Time 125° - 60 °C | | 40 Min. | 11 Min. |
| Dissipation/Mean Temperature Rise (4) | 80°C | 800 Watts/4°C | |
| | 125°C | 1,300 Watts/6°C | |
| | 150°C | 1,400 Watts/6°C | |

- (1) Time to temperature will be slightly longer for lower voltages due to heater kW derating (empty oven).
- (2) Figures are based on a nine-point survey in an empty oven. Uniformity can vary slightly depending on unit and operating conditions.
- (3) Δ In control stability figures represent the change in ambient temperature.
- (4) Dissipation is reduced by 17% on 50-Hertz operation. Temperature gradient/mean temperature rise is with an evenly distributed live load.

Note: Testing performed on 240V-1PH-60HZ.

Power

Line voltages may vary in some geographical locations. If your line voltage is much lower than the oven voltage rating, warm up time will be longer and motors may overload or run hot. If your line voltage is higher than nameplate rating, the motor may run hot and draw excessive amps.

If the line voltage varies more than 10% from the oven voltage rating, some electrical components such as relays, temperature controls, etc. may operate erratically.

WARNING:

Failure to read this warning can result in death, serious bodily injury or property damage. All conductors must be copper unless the specific terminal is marked for use with aluminum conductors.

WARNING:

All grounding and safety equipment must be in compliance with applicable codes, ordinances and accepted safe practices.

Power Requirements

| Volts | Amps | Hertz | Phase | Heater KW |
|-------|------|-------|-------|-----------|
| 208 | 23 | 60 | 1 | 3 |
| 220 | 24 | 50 | 1 | 3.4 |
| 240 | 24 | 60 | 1 | 4 |

THEORY OF OPERATION

Despatch RBC1-50 Burn-In ovens are made for the accelerated life testing of microcircuit electronic devices to identify early mortality. The Despatch RBC1-50 ovens are ideally suited for:

- high-dissipation forward-bias burn-in,
- high temperature reverse-bias burn-in,
- stabilization baking of integrated circuits and other semiconductor devices.

Air atmosphere ovens recirculate air through the chamber. They can add heat and remove dissipated heat. Air is taken from the burn-in room and circulated through the oven. Heat is added by electric resistance elements, or removed through automatically controlled exhaust.

Temperature Control

A Despatch Protocol Plus™ modular microprocessor based digital temperature controller regulates the process. The Protocol Plus™ operates as a dual functioning controller/high limit instrument. The control portion utilizes a time-proportioning voltage signal to control heating, and a milliamp signal to control cooling with minimal temperature fluctuations.

The controller temperature-sensing element, located in the air return plenum area, senses the median air temperature of the oven. The controller automatically controls heat dissipated by sending a signal to the automatic damper modulator. This automatic damper controls the amount of fresh air drawn into the chamber, preventing excessive cooling and conserving energy.

The high limit portion protects the product and/or the oven from overheating. If the product being processed has a critical high temperature limit, the high limit setpoint should be set to a temperature somewhat below the temperature at which the product could be damaged. If the product does not have a critical high temperature limit, the high limit setpoint should be set 5 to 15 degrees higher than the maximum-programmed setpoint at which the oven will operate. When the high limit trips, the alarm horn will signal.

Please refer to the Protocol Plus™ instruction section located in this manual for more detailed information.

Power Switch

The POWER switch controls power to the control circuit, chamber recirculating fan motor relay, control cabinet fan, and any options that were included at the time of purchase.

Air Circulation

A Despatch centrifugal fan draws air through the heater section, moves it evenly across the chamber, past the temperature sensors and back to the heater. The fresh air is controlled manually and a modulating damper controls the exhaust.

Chamber Design

The chamber (in which the load is processed) has air supply and exhaust ducts on opposite sides. The ducts and perforated panels provide uniform airflow and temperature distribution throughout the chamber.

Airflow Switch

The airflow switch senses the differential pressure between the inlet and outlet side of the recirculating fan. If there is no air pressure, the switch disconnects power to the heater, and the alarm horn will signal. An On/Off indicator is visible through a window on the switch. The switch is located in the upper equipment compartment, behind the equipment panel and next to the recirculating motor.

Alarm

When there is a high limit condition, or when there is no air pressure sensed by the airflow switch, an alarm will sound and a red pilot light will be lit. To silence the alarm, depress the momentary ALARM SILENCE switch. The red light will remain on until the alarm condition is cleared.

Chamber Door Handle

The door handle positively engages a cam with a catch in one-quarter turn. The silicone rubber gasket provides a seal around the door as the handle is moved to the latched position.

Damper Control

The oven is equipped with a manually adjustable fresh air damper. The damper blade located on the rear of the oven. The damper adjustment controls the flow of fresh air into the chamber. If the damper is in the full open position, the maximum amount of fresh air is distributed into the chamber.

WARNING: This oven is not designed for use with flammable material. If your process involves flammable material, contact Despatch Industries.

The exhaust has a modulating damper motor, which is automatically controlled by the Protocol Plus™ controller. No adjustments are necessary.

Determining Damper Settings

The optimum setting for the amount of fresh air that should be distributed into the chamber depends on several factors. These factors include ambient environment temperature, load conditions, load distribution, heat up rates, cool down rates, desired temperature uniformity and most importantly the desired operating temperature. To consider all of these variables at any one point in time is not practical and there are engineering tradeoffs that should be considered. Therefore guidelines should be used to determine the fresh air damper setting.

In general, the damper should be set so that the amount of fresh air flowing into the chamber agrees with the desired operating temperature conditions. The following outline shows the considerations involved with various damper position settings.

Full Closed Position

When the fresh air damper is in the full closed position, the chamber will be able to achieve the maximum attainable heat up rates for the chamber. In addition, the chamber will use the minimum amount of power to operate at the desired temperature. In almost all cases, the fresh air damper should be in the full closed position in order to efficiently operate at the maximum operating temperature for the chamber.

Full Open Position

When the fresh air damper is in the full open position, the chamber will operate at its minimum operating temperature.

Friction heat from the air recirculation system builds up in the chamber. This causes chamber temperature to rise slightly even though the heating system is not turned on. After the recirculation motor has been on for an extended period of time, the chamber will reach a thermal equilibrium temperature.

When the damper is not set to the full open position, the chamber has no way to readily dissipate the heat generated by the friction. With the fresh air damper fully open, the thermal equilibrium temperature is the minimum operating temperature of the chamber.

Minimum Opening for Dissipation of Live Load

To determine the minimum setting for the fresh air damper, only open the damper so that the fresh air dissipates the heat from live load. To conserve energy, the cooling output should be trying to control the setpoint temperature with minimal fluctuations. Close the damper if the heater continues to be cycled on and off. If the cooling is full on and the chamber temperature is over the setpoint, open the damper.

Other Damper Settings

The damper can be set to several other distinct operating positions. In most cases, the damper setting is influenced by specific performance factors. Some of these performance factors are uniformity; cool down rates and required dissipation.

The uniformity of the chamber is influenced by the inside chamber pressure of the system. The pressure inside the chamber is dependant on the amount of fresh air flowing into the chamber. When a large volume of fresh air is flowing into the chamber, the chamber becomes slightly pressurized and the overall temperature uniformity improves. The slightly pressurized chamber produces the effect of "pushing" the air to the corners of the chamber. Typically the corners of the chamber will improve with respect to temperature distribution while the core of the chamber will maintain excellent uniformity characteristics regardless of the damper position. Therefore, the pressurization of the chamber typically is a factor when the chamber is loaded heavily. The best uniformity results, with respect to the product, are achieved when the chamber is loaded uniformly.

NOTE: Overpressurizing the chamber can cause hot air to blow out around the door seal and cause the area around the door to be hot to the touch. To stop this hot air from entering the room, close the damper slightly until the air stops blowing.

OVEN INSTRUCTIONS

Failure to heed warnings in this instruction manual and on the oven could result in death, personal injury or property damage.

WARNING:

Do not use oven in wet, corrosive or explosive atmospheres.

Unpacking and Inspection

Remove all packing materials and thoroughly inspect the oven for damage of any kind that could have occurred during shipment.

- See whether the carton and plastic cover sheet inside carton are still in good condition.
- Look at all outside surfaces and corners of the oven for scratches and dents.
- Check the oven controls and indicators for normal movement, bent shafts, cracks, chips or missing parts such as knobs and lenses.
- Check the door and latch for smooth operation.

If there is damage that may have occurred during shipment, follow these instructions.

1. Contact the shipper immediately and file a written damage claim.
2. Contact Despatch Industries to report your findings and to order replacement parts for those that were damaged or missing.
3. Send a copy of your filed damage claims to Despatch.
4. Next, check to make sure you have received all the required materials. Your shipment should include:
 - One (1) Despatch oven
 - One (1) Instruction manual
 - Any special options that were ordered at time of purchase

Warning Signs Missing

If it appears that any warning, danger, caution or information label or sign has been damaged or lost, contact Despatch Industries for replacements. Call or write:

Service Products Division
Despatch Industries
P.O. Box 1320
Minneapolis, MN 55440
Call Toll Free 800-473-7373

Set-up

1. Select the location for installing your oven.
2. Install an exhaust stack from the exhaust discharge stack to the outside of the building, if required.

WARNING:

Do not use the oven in wet, corrosive or explosive atmospheres.

- If a round exhaust stack is used, a minimum area greater than the area of the exhaust stack is required.
- The flashing through the roof or wall must be capable of handling an exhaust stack temperature up to 260°C (500°F).
- All stacks must comply with state and local building codes to insure that surrounding combustible surfaces are below 71°C (160°F).
- Design the exhaust stack to limit the amount of restrictions to insure proper airflow. If more than two (2) elbows are used in the stack, over all airflow will be reduced.

- a. The exhaust could be vented into a burn-in room atmosphere or other exhaust system capable of handling the total rated heat dissipation in:

$$KW \times 3,412 \left(\frac{BTUH}{KW} \right) + 2,500 \left(\frac{BTUH}{KW} \right) \times \text{Recirculation Fan HP}$$

- b. We recommend that the ovens be vented to the outside or to an area that could use the heat. The maximum exhaust temperature could reach the maximum operating temperature of the oven.

3. Place oven on a bench top or directly on the floor. The oven must have a minimum 2-inch clearance in the rear to provide proper ventilation. When placed next to another cabinet, or next to another oven, a 3-inch clearance is required. The doors will still open.
4. Make sure oven is level and plumb; this will assure proper heat distribution and operation of all mechanical components.
5. The atmosphere where the oven is used should be clean, free of solvent vapors. Good results depend on a clean workspace.

Power Connection

Be sure the oven is connected to the power source shown on the nameplate. Connect the oven directly to your electric supply, with all grounding and safety equipment, according to applicable codes, ordinances and accepted safe practices.

Line voltages may vary in some geographical locations. If your line voltage is much lower than the oven voltage rating, the warm up time will be longer and the motors may overload or run hot. If the line voltage varies more than $\pm 10\%$ from the oven voltage rating, the temperature control may operate erratically.

WARNING:

Failure to read this warning can result in death, serious bodily injury or property damage. All conductors must be copper unless the specific terminal is marked for use with aluminum conductors.

WARNING:

All grounding and safety equipment must be in compliance with applicable codes, ordinances and accepted safe practices.

Operating

Users and operators of this oven must comply with operating procedures and training of operating personnel as required by the Occupational Safety and Health Act (OSHA) of 1970, Section 5 and relevant safety standards, and other safety rules and regulations of state and local governments. Refer to the relevant safety standards in OSHA and National Fire Protection Association (NFPA), Section 86 of 1990.

WARNING:

Do not use oven in wet, corrosive or explosive atmospheres.

Loading the Oven

Despatch Industries cannot be responsible for either the process or process temperature used, or for the quality of the product being processed. It is the responsibility of the purchaser and operator to see that the product undergoing processing in a Despatch oven is adequately protected from damage.

Carefully following the instructions in this manual will help the purchaser and operator in fulfilling that responsibility.

Distribute the workload evenly so that airflow is not restricted. Do not overfill your oven. The workload should not take up more than two-thirds of the cross-sectional air-delivery area.

WARNING:

Do not heat any closed containers, flammable solvents or other flammable material in this oven. (Examples: spray can, sealed jar of water, alcohol, kerosene, oil, paper, etc.)

Oven Temperature Limit

Do not attempt to exceed the maximum or minimum operating temperature of this oven.

Product Temperature Limit

If the product has a critical high temperature limit, the HIGH-LIMIT control should be used as a process HIGH-LIMIT. When used as a process HIGH-LIMIT, the control should be set to a temperature somewhat below the temperature at which the product would be damaged. A pyrometer could be used to determine the process HIGH-LIMIT setting. If the destructive temperature of the product is already known, this could be used as a point below which the process HIGH-LIMIT could be set.

NOTE:

Despatch Industries cannot be responsible for either the process or process temperature used, or for the quality of the product being processed. It is the responsibility of the purchaser and operator to see that the product undergoing processing in a Despatch Industries burn-In oven is adequately protected from damage. Carefully following the instructions in this manual will assist the purchaser and operator in fulfilling that responsibility.

Operator Training Requirements

All users must be thoroughly trained under the supervision of experienced personnel. The operator must be aware of the possible dangers of:

- Suffocation from nitrogen,
- Frostbite from nitrogen as a liquid or as a frozen gas,
- Fire.

Users must demonstrate an understanding of the equipment and its operation to assure knowledge of and practice of safe and proper operating procedures. Users should receive regular retraining and testing as required to maintain a high level of proficiency and effectiveness.

Training should include the:

- function of controls and safety devices,
- handling of special atmospheres (on units with LN2 or GN2).

Pre-Startup Checklist

- Know the system. Read this manual carefully. Make use of its instructions and explanations. Safe, continuous, satisfactory, trouble-free operation depends primarily on the degree of your understanding of the system and your willingness to keep all parts in proper operating condition.
- Check line voltage. Voltage must correspond to nameplate requirements of motors and controls. Refer to the section on power connections in the INTRODUCTION of this manual.
- Fresh air and exhaust. Do not be careless about restrictions in and around the fresh air and exhaust openings and stacks. Under no condition permit them to become so filled with dirt that they appreciably reduce the air quantity. The proper ventilation clearances should be fulfilled at all times. Refer to the Set-up instructions in this manual.

Startup

For fastest oven heat-up time, close the fresh-air vent. After the desired temperature is reached, the vent may be adjusted as needed.

1. Start Fan.

- Open oven door.
- Press Power switch to the ON position. You will hear the recirculating fan start.
- Shut oven door.
- Check that the control display turns on.

WARNING:

Do not heat any closed containers, flammable solvents or other flammable material in this oven. (Examples: spray can, sealed jar of water, alcohol, kerosene, oil, paper, etc.)

2. Operate the temperature control as desired by following the Protocol Plus™ instruction section located in this manual for more detailed information.

3. When the oven nears temperature set on the control, the heater will start cycling on and off.

WARNING:

Hot surfaces may exist around door, inside cabinet, product, and fixtures. Handle with care.

4. When the chamber temperature is above setpoint on control, the cooling output of the control will start driving the damper open, which will exhaust air from the chamber.

5. If temperature of the chamber exceeds the high-limit setting on the control, the heater will shut down and the Alarm Horn and red pilot light will energize. The heater will shut off. To silence the alarm:
 - Depress the Alarm Silence switch, this is a momentary switch, it will return to its normal position when released.
 - The alarm horn will be silenced, but the red alarm pilot light will remain lit.
 - When the overtemperature condition clears, press RESET on the control.
 - The heater should be back on and the control should be functioning correctly.
 - If the high-limit trips repeatedly, verify the cause of overtemperature and correct problem.
6. If the fan stops running during process, the Airflow switch will trip and the Alarm Horn and pilot light will energize. The heater will shut off.
 - Shut down the chamber and correct the problem.
7. Shut down chamber by lowering the setpoint on the control, usually to ambient, 20°C (70°F).
8. Turn the power switch to OFF.

WARNING:

On all manual and on all auto processes, the fans should remain in operation until oven temperature is below 150°C (300°F).

PROTOCOL PLUS CONTROLLER

The special features of the Protocol Plus™ control include:

- PID tuning
- Ramp/Soak programming of up to 64 segments
- Segment looping and profile linking
- Built-in manual reset high limit control
- Built-in process timer
- Dedicated LED display for process temperature
- Multi-purpose two-line LCD display with backlight
- Auto-tuning
- Security access
- Process temperature retransmission signal
- Digital inputs for remote profile control
- Optional relay outputs for events, alarms, or end-of-cycle signal
- Optional real-time-clock
- Optional RS232/RS422/RS485 MODBUS communications

Theory of Control Operation

The Protocol Plus is a modular microprocessor based digital temperature controller. The Protocol Plus operates as a dual functioning controller/high limit instrument. The control portion utilizes a time-proportioning voltage signal to control heating devices with minimal temperature fluctuations.

The high limit portion protects the product and/or the oven from overheating. If the product being processed has a critical high temperature limit, the high limit setpoint should be set to a temperature somewhat below the temperature at which the product could be damaged. If the product does not have a critical high temperature limit, the high limit setpoint should be set 5 to 15 degrees higher than the maximum programmed setpoint at which the oven will operate.

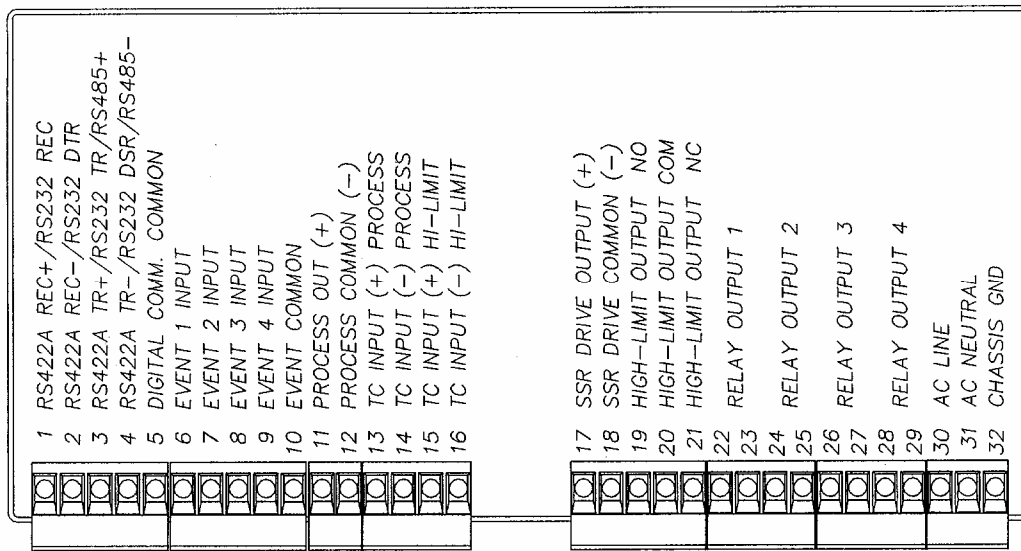
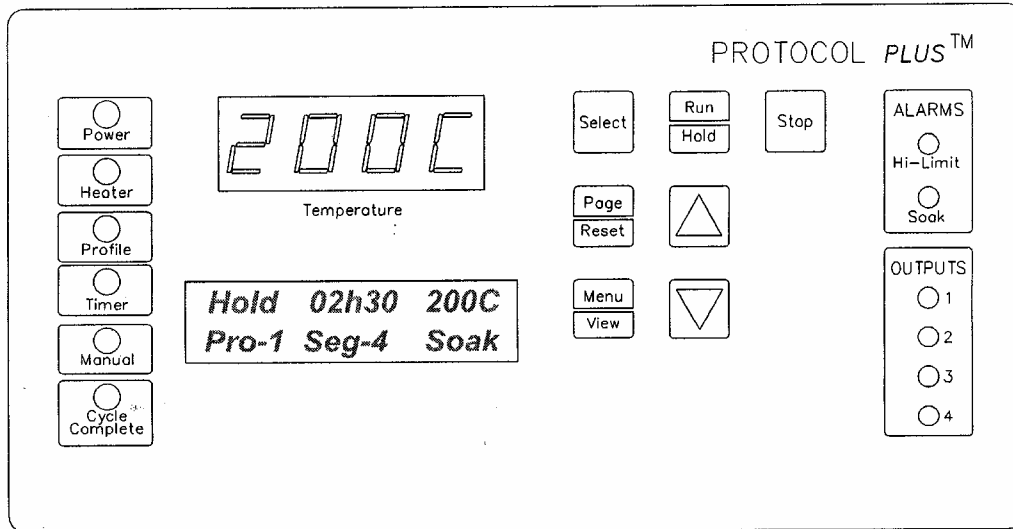

Protocol Plus Faceplate and Wiring Diagram

Operating Modes

The Protocol Plus control has five modes of operation available:

- Stopped Mode:** All control and relay outputs are off. Stopped Mode is integrated into each of the following four modes of operation.
- Manual Mode:** Control operates as a single setpoint control until Stopped mode is accessed
- Timer Mode:** Control operates as a single setpoint control until preset time period has expired.
- Profile Mode:** Control operates as a ramp/soak profiling control until the end of the profile. 8 profiles are available with up to 8 ramp/soak segments in each profile.
- Auto Start Mode (optional):** Control may automatically start Manual, Timer, or Profile mode based on a preset time and day. Requires the optional real-time clock feature.

The optional event outputs can be utilized during Manual, Timer, or Profile modes.

Setup Mode

The control has a Setup Mode which provides access to control configuration and programming of profiles. The Setup Mode contains ten separate electronic Pages where the configuration and programming parameters (Menu items) are found. The Setup Mode Pages are described in detail elsewhere in this manual.

Fast Start Mode

The Protocol Plus control has the ability to automatically start an operating mode when power is applied. This feature may be useful if the same mode of operation is used everyday. The user can turn on the power and the oven will start the desired process automatically. The Fast Start Mode is controlled by the Power-Up Start parameters on the Control page (see Setup Mode).

High Limit

The control has an integrated high limit function which will disable the heater output when tripped. If the high limit does trip, the relay will need to be manually reset. When the high limit relay is tripped, the Hi-Limit indicator will be lit. Allow the oven to cool several degrees (or increase the high limit setpoint) and then press the Reset key. The indicator will turn off.

The control will not allow the high limit setpoint to be set below the current setpoint value.

Indicators

The Protocol Plus control has 12 indicating LEDs that provide operational information to the user.

- X **Power LED:** Indicates that power is supplied to the instrument.
- X **Heater LED:** Indicates that the heater output is active.
- X **Profile LED:** Indicates that the Profile Mode is in operation.
- X **Timer LED:** Indicates that the Timer Mode is in operation.
- X **Manual LED:** Indicates that the Manual Mode is in operation.
- X **Cycle Complete LED:** Indicates that the control is in Stopped mode.
- X **Hi-Limit Alarm LED:** Indicates that the high limit relay has tripped (de-energized).
- X **Soak Alarm LED:** Indicates that the guaranteed soak deviation is in alarm condition.
- X **Outputs 1 through 4:** Indicate that the optional relay outputs are in the ON state. These outputs may be configured as timed event outputs, process temperature trip point outputs, alarm outputs, or as an end of cycle relay output. The ON state can be configured as energized or de-energized.

Displays

The Protocol Plus control has two displays. A dedicated LED upper display shows the oven temperature. A two-line LCD lower display provides information on control status and allows changes to be made to the control settings.

Key Functions

The Protocol Plus control has seven keys that provide operation.

- **Select key:** Press to select mode of operation. In Setup Mode, to select profile number or relay. In Profile/Run Mode, press simultaneously with the UP key to advance a segment.
- **Run/Hold key:** Press to activate a mode of operation. If a Profile (or Timer) Mode is running, pressing the Run/Hold key will place the Profile (or Timer) in Hold status. A subsequent press will resume the Profile (Timer).
- **Stop key:** Press to stop any mode of operation.
- **Page/Reset key:** While in Setup Mode, press to access different Pages of configuration, Press this key to silence an alarm if the instrument alarm sounds during operation. In an operating mode, if an alarm or error condition occurs, press this key to return the instrument to normal operation once the condition is cleared.
- **Menu/View key:** While running any operating mode, pressing this key will display the high limit setpoint. While in Setup Mode, pressing this key will provide access to each Menu parameter.
- **▲▼ keys:** Press these keys to adjust parameter settings. In Profile/Stopped Mode, press to select profile to run. In Profile/Run Mode, press ▲ key simultaneously with the Select key to force the program to advance one segment.

Outputs

The Protocol Plus control has seven different outputs available.

- Heating output:** The control output is a DC voltage open-collector output which is time-proportioned and designed to control a heat control device such as a solid state relay.
- High limit:** The high limit output is a form C relay which is energized under normal operating conditions. If the control senses a temperature higher than the high limit setpoint, or if there is a sensor error, the high limit relay will de-energize until the condition is cleared and the Reset key is pressed. When the high limit relay is de-energized, the heater is disabled.
- Retransmission:** The retransmission output is a DC 0 to 5 volt or 4 to 20 ma (DC) signal that is proportional to the process temperature. The signal can be an input to other devices such as a chart recorder.
- Relay (four optional outputs):** The four form A dry contact relay outputs can be configured to function as alarms, events, or end of cycle. These outputs can be utilized in Manual, Timer, or Profile Mode.

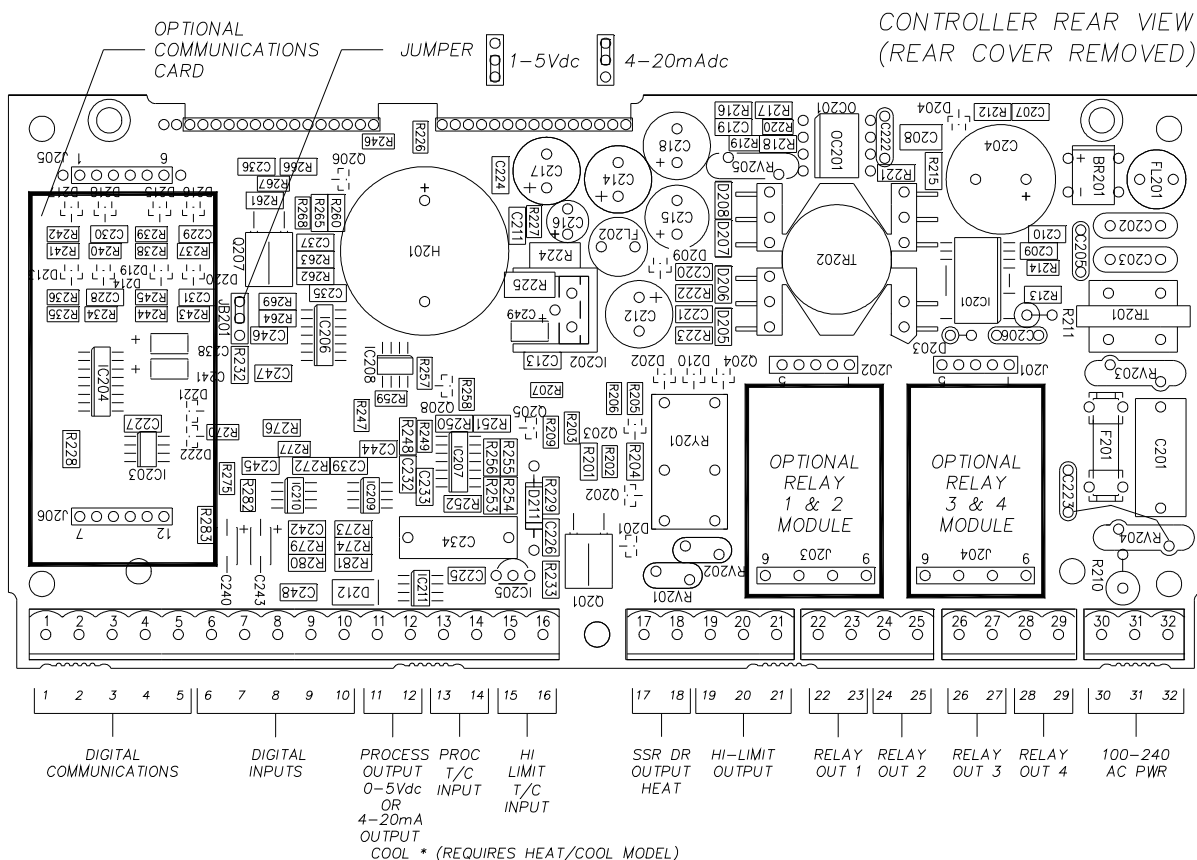

Layout for Optional Components

Relay (Continued)

Use the Relay Card Optional Ay p/n 144562 to add relays to the standard controller. Each relay card contains two relays (maximum of two cards Ay's allowed).

Communication

The Protocol Plus control has optional MODBUS communication available which can communicate via RS232, RS422, or RS485 to a computer. See communications option assembly p/n 141877 for board and cable assembly. Please refer to the MODBUS communications manual which comes with this option.

Optional Software

The Protocol Manager program allows the operator to start/stop multiple ovens (32 maximum) from a personal computer. A data log can also be used to record process information (p.n. 140008).

INSTRUCTIONS

Start-Up

These instructions are provided as a quick reference for operating the Protocol Plus control. If the Profile Mode is to be used, or the configuration of the control needs to be changed, please refer to the Setup Mode instructions before operating the control. For more detailed operating instructions refer to the Operation instructions for the mode you wish to use.

Upon initial power-up the control is in Manual/Stopped Mode (unless the Autostart or Fast Start Modes are active). To activate any operating mode from Stopped Mode, press the Select key until the desired mode is displayed, then press the Run key. If the proper Profile number is not displayed when the Profile Mode is accessed, press the ▲ or ▼ keys until the desired Profile number is displayed, then press the Run key. If no profile numbers can be displayed (display only reads NONE) then no profiles are currently programmed (see Setup Mode).

The temperature setpoint can be adjusted while Manual or Timer Mode is running by pressing the UP or DOWN key.

To momentarily hold the Timer or Profile Mode, press the Hold key. To continue the Timer or Profile Mode, press the Run key.

To return to Stopped Mode at any time, press the Stop key and the cycle complete LED will illuminate.

Note that the control can be configured to automatically activate Manual, Timer or Profile Mode when power is applied (power switch turned on). See Control Page in the Setup Mode to utilize the Fast Start mode.

Operation

Manual Mode

Press the Select key until Manual is displayed (note you can press the Run key at any time to activate Manual Mode).

1. Press the Menu key to display the Process Temperature Setpoint (setpt). You can change the Setpoint with the ▲▼ keys.

Note: If the SPChange parameter on the Enable page in Setup Mode has been set to DISABLED, it must be changed to ENABLED before any changes to the process temperature and high limit setpoints can be made.

2. Press the Menu key a second time to display current high limit setpoint (Hi-Lim SP). The value can be adjusted by pressing the ▲▼ keys. If **Band** is displayed, the high limit band feature is activated (see Control page) and the high limit can not be adjusted.
3. (optional feature) Press the Menu key a third time to display Event1. Press the ▲ key to turn on the event or ▼ to turn off the event. Repeat for all events which are enabled (up to 4).
4. To start Manual Mode, press the Run key.

The display will change from Stop to Run. To return to Stopped Mode, press the Stop key. While in operation, the process setpoint can be adjusted by using the ▲▼ keys to change the value while the mode is running. Pressing the Menu key will display the High Limit Setpoint (HLSP) setting.

If changes to the high limit setpoint or event output configuration are needed, they must be done from the stopped mode.

Timer Mode

1. Press the Select key until Timer is displayed (note you can press the Run key at any time to activate Timer Mode).
2. Press the Menu key to display the Process Temperature Setpoint (Setpt). You can change the Setpoint with the ▲▼ keys.

Note that if the SPChange parameter on the Enable page in Setup Mode has been set to DISABLED, it must be changed to ENABLED before any changes to the process temperature and high limit setpoints can be made.

3. Press the Menu key a second time to display current high limit setpoint (Hi-lim SP). The value can be adjusted by pressing the ▲▼ keys. If **Band** is displayed, the high limit band feature is activated (see Control page) and the high limit can not be adjusted.
4. Press the Menu key a third time to display Time Set. You can change the time setting with the ▲▼ keys.
5. (optional feature) Press the Menu key a fourth time to display Event1. Press the ▲ key to turn on the event or ▼ to turn off the event. Repeat for all events which are enabled (up to 4).
6. Press the Menu key a fifth time to display the current guaranteed soak band (TmrGuarSoak) value. If the process temperature deviates from the setpoint by more than this value, the timer is placed in a hold condition. The timer continues when the process temperature falls within range. Reference the Quick Reference and Default Values section for available settings.
7. To start Timer Mode, press the Run key.

The display will change from Stop to Run and the time remaining will be displayed. To return to Stopped Mode, press the Stop key. While in operation, the process setpoint can be adjusted by using the ▲▼ keys to change the value while the mode is running. Pressing the Menu key will display the High Limit Setpoint.

Pressing the Run/Hold key while the Timer Mode is in operation will put the control in Hold status. The Timer LED will flash to indicate the held status. Press the Run/Hold key again to continue timing. The Timer LED will return to lit status.

Profile Mode

1. Press the Select key until Profile is displayed. "None" may be displayed if a profile has not been selected or no profiles entered.
2. Press the ▲▼ key to display the desired profile to run.
3. To start Profile Mode, press the Run key.

The display will change from Stop to Run and the segment time remaining, Temperature Setpoint, Profile #, along with the current segment number, will be displayed. To return to Stopped Mode, press the Stop key.

Pressing the Run/Hold key while the Profile Mode is in operation will put the control in Hold status. Press the Run/Hold key again to continue the mode. The Profile LED will flash to indicate the hold status.

To advance to the next segment while running a profile, press the Select and UP arrow keys at the same time.

Note that ramping down too fast may cause the high limit relay to trip unexpectedly if the high limit band feature is used. This can be avoided by using a separate cooling profile that does not utilize the high limit band and then jumping to that profile to perform rapid cooling.

Auto Start Mode

The Auto Start Mode allows the control to start Manual, Timer, or Profile mode automatically at a preset time and day. See the Auto Start Page in Setup Mode for the time, day, and operating mode settings. The Auto Start Mode requires the optional Real Time Clock feature for operation.

To activate the Auto Start Mode, the control must first be in Stopped Mode.

1. Press the Select key until Auto Start is displayed.
2. Press the Menu key.
3. Press the ▲▼ keys to activate or deactivate the Auto Start feature.

Note that once you activate Auto Start, you can continue to use all operating modes as normal. If an operating mode is running at the time of a preset Auto Start function, and Auto Start is activated, the existing operating mode will override the auto Start function and the Auto Start will not turn on. To use the Auto Start for the next day, the auto start must show in the LCD display that it is active.

Setup Mode

Configuration of the control and programming of the ramp/soak profiles must be done in the Setup Mode. To access Setup Mode, the control must first be in Stopped Mode.

1. Press the Select key until Setup is displayed.
2. Press the Page key and Security will be displayed.
3. Press the Menu key and Password will also be displayed. Use the ▲▼ keys to enter the proper password.
4. Once the proper password is displayed, press the Page key twice to enter the Setup Mode.

To exit Setup Mode, press and hold the Page key for three seconds.

The control has two levels of password-protected security. Level one provides access only to those menu pages that are enabled on the Enable page. Level two provides access to all menu pages, including the Enable page. The default security password values are 1 for level one and 2 for level two.

If an improper password has been entered, the control will remain at the Security display. To enter the proper password, press the Menu key. To exit Setup Mode, press and hold the Page key for three seconds.

Mapping of the Setup Mode is provided in the following sections. To access each parameter Page, which are described in detail in the following sections, press the Page key until the desired page heading is displayed. Press the Menu key to access each Menu parameter. Press the ▲▼ keys to change Menu parameter settings.

Refer to the Quick Reference and Default Values section for available settings for each Menu parameter.

Press the Page key to continue with each Page, or press and hold the Page key for three seconds to exit Setup Mode.

Instructions for Setup Mode Pages

Program Page

Programming of the profiles is provided on the Program Page. Eight profiles are available with up to eight ramp and soak segments per profile.

If the optional relay outputs are installed, they must be configured as alarms or events on the Relay Outputs Page before they can be utilized. If configured as event outputs, these relays can be used as time or temperature events.

When entering the Program Page, press the Select key to select the profile you wish to enter/edit, then press the Menu key. The first parameter (Profile #, Segment 1, Ramp Time) will display. Adjust the time value with the ▲▼ keys. Once the proper value is displayed, press the Menu key to continue. Continue with the Menu key to adjust/view each parameter.

If the ramp time value of the current segment is left at 0:00, the next press of the Menu key will advance the control to the High Limit Setpoint parameter for that profile. Continue entering / verifying all parameters until you get to the last parameter (Guaranteed Soak Band). Once all parameters have been properly entered, press the Page key to return to the top of the Profile Page. You can press the Select key to enter/edit another profile, press the Page key to access another page, or press and hold the Page key to exit Setup mode.

While editing any profile, pressing the Select key will advance the control to the time value for the next segment, until the last segment has been reached. This allows faster editing of the profile rather than pressing the Menu key to advance past each parameter.

To run a profile indefinitely, link the profile to itself.

| Menu Item | Display | Description |
|--|--------------------------|---|
| Ramp Time Seg 1 | Pro-1 Seg-1 Ramp Time | Ramp time for segment 1 of profile |
| Event 1 Set Value* | Pro-1 Seg-1 Ramp Event 1 | Event 1 setting for segment 1 ramp of profile |
| Event 2 Set Value* | Pro-1 Seg-1 Ramp Event 2 | Event 2 setting for segment 1 ramp of profile |
| Event 3 Set Value* | Pro-1 Seg-1 Ramp Event 3 | Event 3 setting for segment 1 ramp of profile |
| Event 4 Set Value* | Pro-1 Seg-1 Ramp Event 4 | Event 4 setting for segment 1 ramp of profile |
| Soak Temp Seg 1 | Pro-1 Seg 1 Soak Temp | Soak temperature for segment 1 of profile |
| Soak Time Seg 1 | Pro-1 Seg 1 Soak Time | Soak time for segment 1 of profile |
| Event 1 Set Value* | Pro-1 Seg-1 Soak Event 1 | Event 1 setting for segment 1 soak of profile |
| Event 2 Set Value* | Pro-1 Seg-1 Soak Event 2 | Event 2 setting for segment 1 soak of profile |
| Event 3 Set Value* | Pro-1 Seg-1 Soak Event 3 | Event 3 setting for segment 1 soak of profile |
| Event 4 Set Value* | Pro-1 Seg-1 Soak Event 4 | Event 4 setting for segment 1 soak of profile |
| (repeat for segments 2-8, until ramp or soak time = 00:00) | | |
| High Limit Setpoint | Pro-1 Hi-Lim SP | High limit setpoint for profile** |
| Loop From | Pro-1 Loop From Seq | To start a loop action in a profile |
| Loop To | Pro-1 Loop To Seq | To end a loop action in a profile |
| Loop Count | Pro-1 Loop Number | Number of times to execute loop |
| Profile Link | Pro-1 Link To Pro | To jump from this profile to another |
| Guaranteed Soak | Pro-1 Guar Band | Guaranteed soak band for profile |

See the definitions on the following pages for parameter ranges.

* only available if optional relay outputs are installed (repeat all for profiles 2-8)

** Set to **Band** to use the high limit band feature

| | |
|-----------------------------|---|
| Profile # | There are eight profiles available. |
| Segment# | Recipe segments 1 through 8 may be programmed, each with its own set of events, ramp and soak times, and soak temperature. |
| Ramp Time | The time required to ramp from one setpoint up to another setpoint. Values between 0 and 99:59 are allowable. In the Protocol Plus controller, the profile ramp and soak times are stored without units. Units are set as either hours and minutes (HH:MM) or minutes and seconds (MM:SS). The setpoint will automatically increment from the actual temperature to the soak temperature. |
| EV1 through 4 | From 1 to 4 events may be programmed into the ramp time portion of each segment here. These typically involve actuating/disabling relays to close/open valves or perform other relay-controlled functions. NOTE: These will only actuate when the controller has the relay cards installed and programmed for an event. |
| Soak Temp. | The temperature setpoint of a particular segment is entered here; it can range from -18 to 540 degrees C (0 to 1000 degrees F). |
| Soak Time | The duration of soak is entered here; the value can range from 0 to 99:59. |
| EV1 through 4 | From 1 to 4 events may be programmed into the soak portion of each segment here. These typically involve actuating/disabling relays to close/open valves or perform other relay-controlled functions. NOTE: These will only actuate when the controller has the relay cards installed and programmed for an event. |
| Hi Limit SP | The high limit setpoint may be entered here; if the temperature exceeds this value, the hi-limit will alarm and shut off the heater. |
| Loop From | Values are No, Seq-1 to Seq-8. |
| Loop To | Values are No, Seq-1 to Seq-8. |
| Loop Number | Values are 0 - 99. These values enable the operator to jump from a certain step to another step of the recipe a preset number of times. |
| Profile Link | Values are STOP/HOLD/1 - 8. When the profile ends, the profile can turn the heater off, hold the temperature setpoint at the end of the profile, or jump to another specified profile. |
| Guaranteed Soak Band | If the process temperature deviates from the setpoint by more than this value, the soak timer is placed in a hold condition. The timer continues when the process temperature falls within range. |

Sample Profile

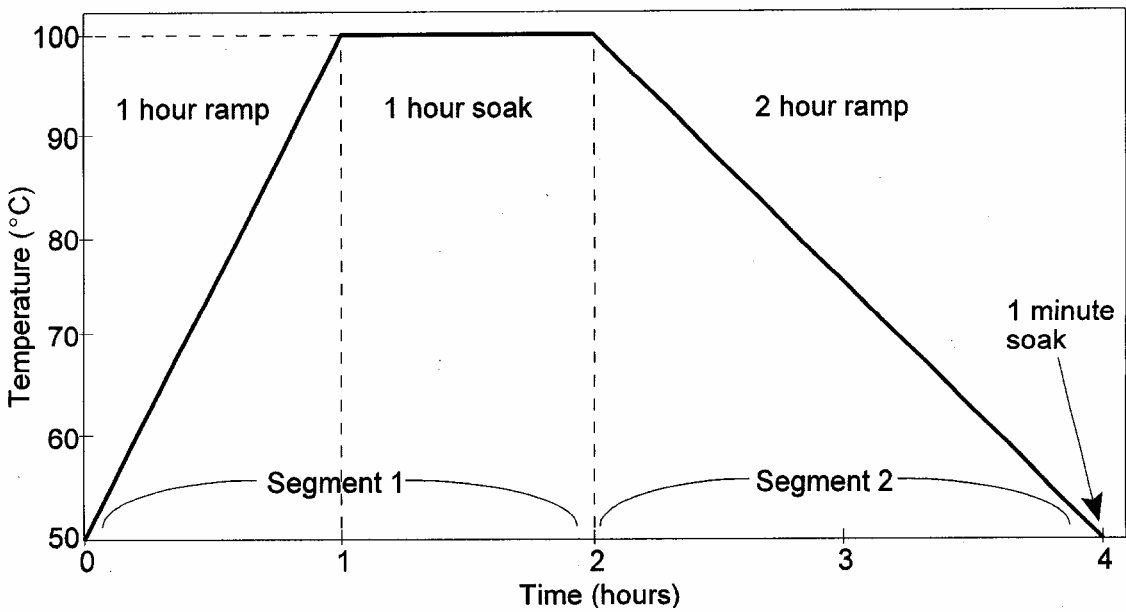

Programming Table

Profile Number 1

Profile Name _____

| Segment | Ramp | | | | Soak | | | | | | |
|---------------------|-------|--------|---|-----|------|-------------|-------|--------|---|---|---|
| | Time | Events | | | | Temperature | Time | Events | | | |
| | | 1 | 2 | 3 | 4 | | | 1 | 2 | 3 | 4 |
| 1 | 01h00 | | | | | 100 | 01h00 | | | | |
| 2 | 02h00 | | | | | 50 | 00h01 | | | | |
| 3 | 00h00 | | | | | | | | | | |
| 4 | | | | | | | | | | | |
| 5 | | | | | | | | | | | |
| 6 | | | | | | | | | | | |
| 7 | | | | | | | | | | | |
| 8 | | | | | | | | | | | |
| High Limit Setpoint | | | | 115 | | | | | | | |
| Loop From Seq | | | | No | | | | | | | |
| Loop To Seq | | | | No | | | | | | | |
| Loop Number | | | | 0 | | | | | | | |
| Link To Pro | | | | No | | | | | | | |
| Guar Soak Band | | | | 10 | | | | | | | |

Auto Start Page (optional)

If the optional real time clock has been installed, the Auto Start Page can be configured to automatically start Manual, Timer or Profile Mode at a specified time and day. Note that if Auto Start Enable is set to Yes in the Setup Mode, the Auto Start feature is not turned on - it is available to the operator to be activated in Stopped Mode.

To configure the Auto Start feature:

1. Access the Setup Mode.
2. Press the Page key until Auto Start is displayed.
3. Press the Menu key. If there is no change in the display, the controller may not have the realtime clock option.
4. Set Auto Start Enable to Yes.
5. Using the Menu key, scroll through the options available and use the ▲▼ keys to set the mode desired for each day of the week. You may select from Manual, Timer, or Profile 1 through 8.
6. When the mode is set press the Menu key.
7. Enter the time of day you wish the mode to activate.
8. Continue through the rest of the week by pressing the Menu key, or press the Page key when done.

One Auto Start mode can be set for each day of the week. Exit the Setup mode by pressing and holding the Page key for three seconds. Press the Select key until Auto Start is displayed. Make sure the correct time and day is displayed. If not proper, set it to the correct time on the Real Time Clock Page in the Setup mode. Press the Run key to activate Auto Start. The display will change from Stop to Active. When the preset time and day occurs, the appropriate operating mode will start. You can de-activate Auto Start by pressing the Select key until Auto Start is displayed, then pressing the Stop key.

Note that once you activate Auto Start, you can continue to use all operating modes as normal. If an operating mode is running at the time of a preset Auto Start function, and Auto Start is activated, the existing operating mode will override the Auto Start function and the Auto Start will not turn on.

| Menu Item | Display | Description | Range |
|------------------|---------------------|---|------------------------------------|
| Enable Autostart | Auto Start Enable | Enable (yes) or disable (no) the Autostart function | No, Yes |
| Sunday mode | Auto Start Sun Mode | Set mode on Sunday to activate | Off, Manual, Timer, Pro-1 to Pro-8 |
| Sunday time | Auto Start Sun Time | Set time on Sunday for mode to activate | 00:00 to 23:59 |
| Monday mode | Auto Start Mon Mode | Set mode on Monday to activate | Off, Manual, Timer, Pro-1 to Pro-8 |
| Monday time | Auto Start Mon Time | Set time on Monday for mode to activate | 00:00 to 23:59 |
| Tuesday mode | Auto Start Tue Mode | Set mode on Tuesday to activate | Off, Manual, Timer, Pro-1 to Pro-8 |
| Tuesday time | Auto Start Tue Time | Set time on Tuesday for mode to activate | 00:00 to 23:59 |
| Wednesday mode | Auto Start Wed Mode | Set mode on Wednesday to activate | Off, Manual, Timer, Pro-1 to Pro-8 |
| Wednesday time | Auto Start Wed Time | Set time on Wednesday for mode to activate | 00:00 to 23:59 |
| Thursday mode | Auto Start Thu Mode | Set mode on Thursday to activate | Off, Manual, Timer, Pro-1 to Pro-8 |
| Thursday time | Auto Start Thu Time | Set time on Thursday for mode to activate | 00:00 to 23:59 |
| Friday mode | Auto Start Fri Mode | Set mode on Friday to activate | Off, Manual, Timer, Pro-1 to Pro-8 |
| Friday time | Auto Start Fri Time | Set time on Friday for mode to activate | 00:00 to 23:59 |
| Saturday mode | Auto Start Sat Mode | Set mode on Saturday to activate | Off, Manual, Timer, Pro-1 to Pro-8 |
| Saturday time | Auto Start Sat Time | Set time on Saturday for mode to activate | 00:00 to 23:59 |

PID Page

The PID Page contains parameters which control the response to the setpoint and process variable input. To access the PID Page, enter the Setup Mode (see description earlier in this manual). Press the Page key until PID is displayed. Press the Menu key. Each parameter can be changed by pressing the Menu key until the desired parameter is displayed, and then pressing the ▲▼ keys to change the value.

| Menu Item | Display | Description | Range |
|-------------------|-------------------|----------------------------------|-------------------------|
| Display units | PID Temp Unit | Set display units to °C or °F | °C or °F |
| Proportional band | PID Prop Band | Set proportional band for tuning | 1 to 56°C (1 to 100°F) |
| Integral reset | PID Reset/Rep/Min | Set integral reset for tuning | 0 to 100 seconds/repeat |
| Derivative Rate | PID Rate In Sec | Set derivative rate for tuning | 0 to 500 seconds |
| AutoTune | PID AutoTune | Enable auto tuning function | Disable, Enable |

The AutoTune parameter disables or enables the AutoTune function. To utilize AutoTuning:

1. Access the Setup Mode.
2. Press the Page key until the display reads AutoTune. Press the ▲ key to enable the AutoTune.
3. Press the Page key for three seconds to exit Setup Mode.
4. Cycle power to the instrument.
5. Set Manual Mode to run. The display will alternately display AutoTune and Manual.

If the Manual Mode setpoint is less than 50 degrees higher than the actual process temperature, the AutoTune function will create an error condition. This can be cleared by either cooling off the process temperature or increasing the setpoint until there is more than 50 degrees between them. Once the AutoTune function is allowed to complete tuning, the AutoTune parameter will disable by itself.

If you wish to cancel the AutoTune function, press the STOP key, access the PID page in Setup Mode, and set the AutoTune parameter to Disable.

Control Page

The Control Page contains various parameters which control miscellaneous functions. To access the Control Page, enter the Setup Mode. Press the Page key until Control is displayed. Press the Menu key. Each parameter can be changed by pressing the Menu key until the desired parameter is displayed, and then pressing the ▲▼ keys to change the value.

| Menu Item | Display | Description | Range |
|----------------------|------------------------|--|------------------------------------|
| Cycle Time | Control Cycle Time Sec | Set cycle time in seconds for control output | 1 to 60 seconds |
| High limit setpoint | Control Hi-Lim SP*** | Maximum value for all high limit setpoints | MinHiLimSP - MaxHiLimSP* |
| High limit band | Control Hi-Lim Band | If=0, high limit setpoint= Control Hi-Lim SP If>0, high limit setpoint= Control SP* + Band | Off, 3°C to 11°C (5°F to 20°F) |
| Power fail recovery | Control PwrFRec | Controls response to loss of power | Stop, Restart, Hold, Resume |
| Recovery time limit | Control PFRTIME**** | Control aborts to Stopped mode if power is lost for time period longer then set value | 00m00s to 99m59s |
| Powerup start enable | ControlPwrUpStrt | Allows mode to automatically start when power is first applied | Disable, Enable |
| Powerup Start Mode | Control StrtMode | Operating mode for powerup start | Off, Manual, Timer, Pro-1 to Pro-8 |
| Hysteresis | Control Hysteresis | Hysteresis for all alarms and temperature events | 1°C to 56°C (1°F to 100°F) |
| Process out low | Control RetOutLo | Process value for retransmit output = 1VDC | -73°C to 760°C (-100°F to 1400°F) |
| Process out high | Control RetOutHi | Process value for retransmit output = 5VDC | -73°C to 760°C (-100°F to 1400°F) |
| Time scale | Control TimeScale | Time scale setting for program and timer mode** | hh:mm or mm:ss |
| Key press beep | Control KeyBeep | Internal beeper sounds when key is pressed | On or Off |
| End of cycle beep | Control EOCSBeep | Internal beeper sounds at end of cycle | On or Off |
| Alarm beep | Control AlarmBeep | Internal beeper sounds for alarms | On or Off |

* includes ramping setpoints during profiles and controlled ramps

** power fail recovery time limit is always MM:SS regardless of time scale setting

*** high limit setpoint is a read-only item which is calculated on Enable page

**** requires real-time-clock feature

Communication Page (optional)

The Communication Page contains parameters for the communications feature. To access the Communications Page, enter the Setup Mode (see description earlier in this manual). Press the Page key until Communication is displayed. Press the Menu key. Each parameter can be changed by pressing the Menu key until the desired parameter is displayed, and then pressing the ▲▼ keys to change the value.

| Menu Item | Display | Description | Range |
|-----------|------------------------|-------------------------------|--------------------------------|
| Address | Communication CommAddr | Sets address node for control | 1 to 255 |
| Mode | Communication Mode | Turns on/off communications | OFF, Modbus |
| Baud Rate | Communication BaudRate | Sets interface speed | 2400, 4800, 9600, 19.2K, 38.4K |
| Parity | Communication Parity | Sets parity for interface | None, Odd, Even |

Real Time Clock Page (optional)

The Real Time Clock Page allows the control to be configured to have an operating mode begin automatically at a specific time on a specific day of the week. The real time clock feature is required for using the Power Failure Recovery mode Time Limit feature (see Control Page). The real-time-clock is a seven day, 24 hour clock with battery backup.

To access the Real Time Clock Page, enter the Setup Mode. Press the Page key until Clock is displayed. Press the Menu key. (If there is no change in the display, the controller may not have the realtime clock option.) Each parameter can be changed by pressing the Menu key until the desired parameter is displayed, and then pressing the ▲▼ keys to change the value.

| Menu Item | Display | Description | Range |
|-----------------|------------------------|--|-----------------------------------|
| Day of the week | Clock Day | Setting for current day of the week | Sun, Mon, Tue, Wed, Thu, Fri, Sat |
| Time of day | Clock HH:MM | Setting for current time of the day | 00:00 to 23:59 |
| Reset clock | Clock UP to Reset CLK* | Press the ▲ key to set the clock to entered values | Ready, Done |

* If the ▲ key is not pressed, the clock values will retain their original values. The display will change to Done if the clock is reset

Relay Outputs Page (optional)

The Relay Outputs Page configures the four alarm/event outputs. Each output has a dedicated indicator light and can be configured as a temperature alarm, profile event, or end of cycle output. Temperature alarms can be of type process high, process low, deviation high, deviation low, or deviation band.

To access the Relay Page, enter the Setup Mode (see description earlier in this manual). Press the Page key until Relay is displayed. Press the Select key until the desired relay output is selected. Press the Menu key. Each parameter can be changed by pressing the Menu key until the desired parameter is displayed, and then pressing the ▲▼ keys to change the value. To configure a specific relay, press the Select key until the desired relay appears.

NOTE: If Relay 0 appears, then no relays are installed (see relay kit assembly p.n. 144562).

| Menu Item | Display | Description | Range |
|-------------------|------------------------|--|-----------------------------------|
| Type of relay | Relay 1 RelayType | Set function of relay | Off, Alarm, Cycl, Ev1 to Ev4 |
| Action of relay | Relay 1 RelayAction | Set coil and contact state of relay | NDE, NE, NDEL, NEL ***** |
| Type of alarm* | Relay 1 AlarmType | Set alarm type for relay | High, Low, Plus, Minus, Band |
| Alarm setpoint* | Relay 1 AlmHi/Lo SP | Setpoint for alarm | -73°C to 760°C (-100°F to 1400°F) |
| Alarm deviation* | Relay 1 AlmDevBand | Deviation band for alarm | 1 to 56°C (1 to 100°F) |
| Inhibit alarm* | Relay 1 ALMInhibit | Inhibits alarm until "safe" condition is reached | En or Dis |
| Type of event** | Relay 1 EventType | Set event type for relay | Time or Temp |
| Event setpoint*** | Relay 1 Event SP | Setpoint for temperature event | SPLoLim to SPUPLim***** |

(repeat for relay outputs 2-4, if available)

* appears only for alarm types

** appears only for time or temperature event types

*** appears only for temperature event types

Turning on the Alarm Inhibit function disables the alarm output on power up until the process temperature has reached a non-alarming condition ("safe").

If the relay output has been configured as latching, the RESET key must be pressed to return the output to the non-alarm state once the alarm condition has cleared.

Test Page

The Test Page contains parameters which allow manual control of the heat control and optional relay outputs and should be used only for testing the functionality of the control instrument. Do not operate the oven for processes using the Test Page.

To access the Test Page, enter the Setup Mode (see description earlier in this manual). Press the Page key until Test is displayed. Press the Menu key. Each parameter can be changed by pressing the Menu key until the desired parameter is displayed, and then pressing the ▲▼ keys to change the value.

| Menu Item | Display | Description | Range |
|------------------|---------------------------------|---|-------|
| Heater output | Test HeatOut | Activate SSR output 100% | On |
| High limit relay | Test HiLimOut | Activate high limit alarm (de-energize relay) | On |
| Relay 1 output | Test Rly1 Out | Energize relay output 1 | On |
| Relay 2 output | Test Rly2 Out | Energize relay output 2 | On |
| Relay 3 output | Test Rly3 Out | Energize relay output 3 | On |
| Relay 4 output | Test Rly4 Out | Energize relay output 4 | On |
| HiLim Sensor | Test HL Temp (push and hold up) | Displays sensor reading* | |

*Push ▲ key to refresh display

When the Test Page is entered, all outputs are automatically set to off. When exiting the Test Page, all outputs will return to their previous condition regardless of the Test Page settings.

Zone Calibration Page

The Zone Calibration Page allows adjustment of the displayed temperature versus the actual temperature measured by the control thermocouple. This may be desirable in certain conditions where the center of the oven chamber is not the same temperature as the control thermocouple. This may occur when the oven is not allowed to soak at a constant temperature for long periods of time, or the oven is being used at high temperature.

There is also a Factory Calibration Recovery which will restore the factory calibration values when the control was first shipped by the manufacturer. This may be helpful if the calibration has been lost and a calibration instrument is not readily available. To use the Factory Calibration Recovery feature only, bypass the Zone 1 and Zone 2 calibration parameters by pressing the Menu key.

To access the Zone Calibration Page, enter the Setup Mode (see description earlier in this manual). Press the Page key until Zone Cal is displayed. Press the Menu key. Each parameter can be changed by pressing the Menu key until the desired parameter is displayed, and then pressing the ▲▼ keys to change the value.

| Menu Item | Display | Description | Range |
|----------------------|----------------------|--|-----------------------------------|
| Zone 1 actual | Zone Cal Zone1Act | Point at which Zone 1 is set (center of chamber) | -73°C to 760°C (-100°F to 1400°F) |
| Zone1 displayed | Zone Cal Zone1Dis | Desired displayed value for Zone 1 setting | -73°C to 760°C (-100°F to 1400°F) |
| Zone 2 actual | Zone Cal Zone2Act | Point at which Zone 2 is set (center of chamber) | -73°C to 760°C (-100°F to 1400°F) |
| Zone2 displayed | Zone Cal Zone2Dis | Desired displayed value for Zone 2 setting | -73°C to 760°C (-100°F to 1400°F) |
| Factory calibration* | Zone Cal FactCal | Restores the factory calibration values | Ready or Done (push- key) |

*Only use when no calibration instrument is available, push ▲ key to restore factory values.

Press the Page key to exit the Zone Calibration Page.

Two points of display calibration (temperature offset) are available. The Zone 1 Actual and Zone 2 Actual parameters are the two temperature points where the offset is to take effect. These values are adjustable. The Zone 1 and Zone 2 Displayed parameters are the values the user wishes to have displayed at the Actual temperatures, and are also adjustable.

As an example, the control is displaying 400°F with the setpoint being 400°F, but the center of the oven chamber is actually 395°F. This can occur due to oven wall losses and product loading variations. The operator may change the zone calibration so that the center of the oven is 400°F when the display reads 400°F. In this case operate the oven in manual mode with a setpoint of 400°F. Record the center of the chamber (as measured with an independent sensor). Access the Zone Calibration Page and enter this measured value as the Zone 2 Actual value, with 400° as the Zone 2 Displayed value.

Zone 1 can be adjusted using the same method at a lower temperature. The instrument will then create a linear offset based on the Zone 1 and Zone 2 Actual temperature values. Note that the oven does not have to be heated to adjust the zone parameters if the zone values are known based on prior experience.

Sensor Calibration Page

The Sensor Calibration Page has parameters which can change the internal calibration of the temperature sensor input signal. There is a low and high calibration point for both the control sensor and the high limit sensor. To calibrate the instrument, allow the control to warm up for at least 30 minutes.

To access the Sensor Calibration Page, enter the Setup Mode (see description earlier in this manual). Press the Page key until Control Sensor is displayed. Press the Menu key.

The control may have the optional process value retransmission output feature. The output is a 1 to 5VDC signal. To calibrate the retransmit signal, the RetOutLo and RetOutHi values from the Control Page must be known. You may bypass calibrating the control and high limit sensor input to access only the retransmit calibration by pressing the Menu key until RetCalLo is displayed (skip steps 4-17).

To re-calibrate the instrument:

1. Disconnect the control and high limit sensor thermocouples.
2. Connect a calibration instrument with a type J thermocouple output to the control sensor input. Allow the control to warm up at least 30 minutes.
3. Access Setup Mode.
4. Press Page key until **-100F** is displayed.
5. Press Menu key until **Ctrl Sens -100F** is displayed.
6. With **Ctrl Sens -100F** displayed, adjust the calibration instrument to Type J thermocouple, -100 degrees Fahrenheit output.
7. Wait 30 seconds. Press the ▲ key.
8. With **Ctrl Sens 1400F** displayed, adjust the calibration instrument to 1400 degrees Fahrenheit output (Type J thermocouple).
9. Wait 30 seconds. Press the ▲ key.
10. When the control displays **Ctrl Sens Done**, disconnect the calibration instrument from the control sensor input and connect it to the high limit sensor input. Reconnect the control sensor thermocouple.
11. Press the Menu key until **HL Sens -100F** is displayed.
12. With the control displaying **HL Sens -100F**, adjust the calibration instrument to -100 degrees Fahrenheit output (Type J thermocouple).
13. Wait 30 seconds. Press the ▲ key.
14. With the control displaying **HL Sens 1400F**, adjust the calibration instrument to 1400 degrees Fahrenheit output (Type J thermocouple).
15. Wait 30 seconds. Press the ▲ key.
16. When the control displays **HL Sens Done**, disconnect the calibration instrument from the high limit sensor input. Re-connect the high limit sensor thermocouple.
17. To skip calibration of the retransmit signal, press the Page key twice to exit the Sensor Calibration Page.
18. To calibrate the retransmit signal, press the Menu key until **RetCalLo** is displayed.

19. Connect a calibration instrument with a type J thermocouple output to the control sensor input.
20. Connect a voltage measurement device to the retransmit output terminals.
21. Set the calibration instrument output to the temperature value of the **RetOutLo** parameter from the Control Page.
22. Adjust the **RetCalLo** * value using the ▲▼ keys until the voltage measurement device reads 1VDC.
23. Press the Menu key.
24. Set the calibration instrument output to the temperature value of the **RetOutHi** parameter from the Control Page.
25. Adjust the **RetCalHi** * value using the ▲▼ keys until the voltage measurement device reads 5VDC.
26. Press the Menu key.
27. Press the Page key to exit the Sensor Calibration Page.
28. Calibration is now complete. Disconnect the calibration instrument and voltage measurement device (if used).
29. Verify that the control and high limit sensor thermocouples are connected.

| Menu Item | Display | Description | Range |
|--------------------|-----------------|----------------------------------|----------------|
| Control Sensor Cal | Ctrl Sens -100F | Calibrate Sensor Low End | -100 to 1400°F |
| | Ctrl Sens 1400F | Calibrate Sensor High End | -100 to 1400°F |
| | Ctrl Sens Done | Control Sensor Cal Complete | (read only) |
| HiLim Sensor Cal | HL Sens -100F | Calibrate HiLim Sensor Low End | -100 to 1400°F |
| | HL Sens 1400F | Calibrate HiLim Sensor High End | -100 to 1400°F |
| | HL Sens Done | HiLim Sensor Cal Complete | (read only) |
| Retransmit Cal | RetCalLo XXXX * | Calibrate Retransmit Output Low | 0 to 4096** |
| | RetCalHi XXXX * | Calibrate Retransmit Output High | 0 to 4096*** |

*Note that the actual RetCalLo and RetCalHi values displayed are of no importance.

Enable Page

The Enable Page controls access to the other Setup Pages. The setpoint minimum and maximum values, and the security passwords are also set on the Enable Page.

To access the Enable Page, enter the Setup Mode using a level 2 access code (see description earlier in this manual). Press the Page key until Enable is displayed. Press the Menu key. Each parameter can be changed by pressing the Menu key until the desired parameter is displayed, and then pressing the ▲▼ keys to change the value.

NOTE: Changing the enable to “yes” for each page will allow access to the page in Level 1 security.

| Menu Item | Display | Description | Range |
|----------------------|----------------------|---|-----------------------------------|
| Profiles | Enable Profile 1-8 | Controls access to Program Page | Yes or No |
| Autostart | Enable Auto Start | Controls access to AutoStart Page | Yes or No |
| PID | Enable PID | Controls access to PID Page | Yes or No |
| Control | Enable Control | Controls access to Control Page | Yes or No |
| Communication | Enable Communication | Controls access to Communication Page | Yes or No |
| Real Time Clock | Enable Clock | Controls access to Real Time Clock Page | Yes or No |
| Relay outputs | Enable Relay 1-4 | Controls access to Relay Page | Yes or No |
| Test | Enable Test | Controls access to Test Page | Yes or No |
| Zone Calibration | Enable Zone Cal | Controls access to Zone Calibration Page | Yes or No |
| Sensor Calibration | Enable Sensor Cal | Controls access to Sensor Calibration Page | Yes or No |
| Setpoint lower limit | Enable SPLowerLim | Sets minimum setpoint allowed | -73°C to 760°C (-100°F to 1400°F) |
| Setpoint upper limit | Enable SPUpperLim | Sets maximum setpoint allowed | -73°C to 760°C (-100°F to 1400°F) |
| High limit overhead | Enable HiLimOH | Sets maximum high limit setpoint allowed* | 3 to 11°C (5 to 20°F)* |
| Password level 1 | Enable Password 1 | Sets password for access level 1 | 0 to 1000 |
| Password level 2 | Enable Password 2 | Sets password for access level 2 | 0 to 1000 |
| Setpoint Change | Enable SPChange | Set to DISABLE to lock out setpoint and high limit setpoint changes in Manual and Timer Modes | Yes or No |
| Analog Output Type | Enable Analog Type | Sets Analog Output type | Ctrl or Proc |

* Maximum high limit setpoint = SPUpperLim + HiLimOH

Digital Inputs (optional)

The Protocol Plus control can be run by external inputs wired to the control from an external source such as a PLC or control panel switches. The external run operation can Run, Hold or Stop profiles 1 through 7 (profile 8 can not be operated externally). Refer to the table below for the inputs required for the desired operation. NOTE: A profile must be created in the program page before trying to run a profile number.

| Input 1 | Input 2 | Input 3 | Profile Selected |
|---------|---------|---------|------------------|
| ON | OFF | OFF | 1 |
| OFF | ON | OFF | 2 |
| ON | ON | OFF | 3 |
| OFF | OFF | ON | 4 |
| ON | OFF | ON | 5 |
| OFF | ON | ON | 6 |
| ON | ON | ON | 7 |
| OFF | OFF | OFF | none |

To start the selected profile, set Input 1, 2, 3 or 4 to ON.

To hold a profile, set Input 4 to OFF.

To stop a profile, set all inputs to OFF.

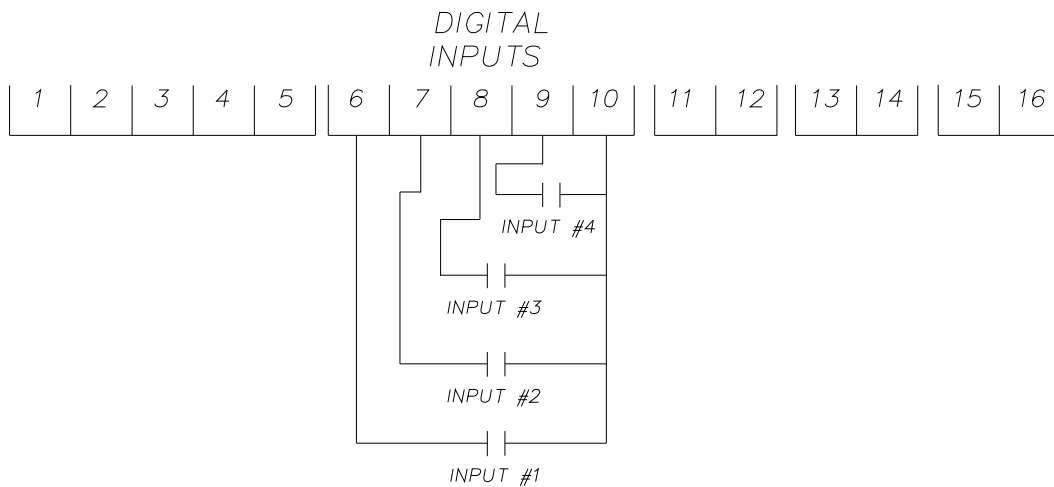

Digital Inputs

Error Messages and Alarms

The Alarm Status **Hi-limit** LED is flashing. This indicates a problem with the thermocouple, or the Hi-limit setpoint has been exceeded. Once the problem has corrected, press the Reset pushbutton.

The Alarm Status **Soak** LED is flashing. This indicates that the oven temperature has not entered or dropped out of the soak band and the soak timer has stopped.

The top LED Display reads **OPEN**. This indicates that either the Control or the Hi-limit thermocouple is disconnected or broken. The lower LCD display should indicate which thermocouple is the problem. Repair or replace the thermocouple.

The lower LCD display reads **CONTROL SENS ERR**. This indicates that the Control thermocouple is disconnected or broken. The upper LED display should indicate OPEN showing a thermocouple problem. Repair or replace the thermocouple.

The lower LCD display reads **HI-LIM SENS ERR**. This indicates that the Hi-limit thermocouple is disconnected or broken. Repair or replace the thermocouple.

The lower LCD display reads **HIGH LIMIT ALARM**. This indicates that the Hi-limit temperature setpoint has been exceeded. Determine if the setting is set too close to the setpoint, the SSR is defective, or the calibration is incorrect.

Quick Reference and Default Values

Program Page

| Menu Item | Display | Default | Range | Setting |
|---------------------------|--------------------------|-------------|-------------------------------------|---------|
| Ramp Time Seg 1 | Pro-1 Seg-1 Ramp Time | 00:00 | 00m00s to 99h59s | |
| Event 1 Set Value | Pro-1 Seg-1 Ramp Event 1 | Off | Off, On | |
| Event 2 Set Value | Pro-1 Seg-1 Ramp Event 2 | Off | Off, On | |
| Event 3 Set Value | Pro-1 Seg-1 Ramp Event 3 | Off | Off, On | |
| Event 4 Set Value | Pro-1 Seg-1 Ramp Event 4 | Off | Off, On | |
| Soak Temp Seg 1 | Pro-1 Seg 1 Soak Temp | 68°F | SPLowerLim to SPUpperLim * | |
| Soak Time Seg 1 | Pro-1 Seg 1 Soak Time | 00:00 | 00m00s to 99h59s | |
| Event 1 Set Value | Pro-1 Seg-1 Soak Event 1 | Off | Off, On | |
| Event 2 Set Value | Pro-1 Seg-1 Soak Event 2 | Off | Off, On | |
| Event 3 Set Value | Pro-1 Seg-1 Soak Event 3 | Off | Off, On | |
| Event 4 Set Value | Pro-1 Seg-1 Soak Event 4 | Off | Off, On | |
| (repeat for segments 2-8) | | | | |
| High Limit Setpoint | Pro-1 Hi-Lim SP | Max HiLimSP | MinHiLimSP to MaxHiLimSP *, Band ** | |
| Loop From | Pro-1 Loop From XX | No | No, Seg-1 to Seg-8 | |
| Loop To | Pro-1 Loop To XX | No | No, Seg-1 to Seg-8 | |
| Loop Count | Pro-1 Loop Number | 0 | 0 to 99 | |
| Profile Link | Pro-1 Link To XX | Stop | Stop, Hold, Pro-1 to Pro-8 | |
| Guaranteed Soak | Pro-1 Guar Band | Off | Off, 1 to 760°C (1400°F) | |
| (repeat for profiles 2-8) | | | | |

* See Enable Page

** Band value is set on Control Page

Programming Table

Profile Number _____

Profile Name _____

| Segment | Ramp | | | | | Soak | | | | | |
|---------------------|------|--------|---|---|---|-------------|------|--------|---|---|---|
| | Time | Events | | | | Temperature | Time | Events | | | |
| | | 1 | 2 | 3 | 4 | | | 1 | 2 | 3 | 4 |
| 1 | | | | | | | | | | | |
| 2 | | | | | | | | | | | |
| 3 | | | | | | | | | | | |
| 4 | | | | | | | | | | | |
| 5 | | | | | | | | | | | |
| 6 | | | | | | | | | | | |
| 7 | | | | | | | | | | | |
| 8 | | | | | | | | | | | |
| High Limit Setpoint | | | | | | | | | | | |
| Loop From Seq | | | | | | | | | | | |
| Loop To Seq | | | | | | | | | | | |
| Loop Number | | | | | | | | | | | |
| Link To Pro | | | | | | | | | | | |
| Guar Soak Band | | | | | | | | | | | |

Autostart

| Menu Item | Display | Default | Range | Setting |
|------------------|---------------------|---------|------------------------------------|---------|
| Enable Autostart | Auto Start Enable | No | No, Yes | |
| Sunday mode | Auto Start Sun Mode | Off | Off, Manual, Timer, Pro-1 to Pro-8 | |
| Sunday time | Auto Start Sun Time | 00:00 | 00:00 to 23:59 | |
| Monday mode | Auto Start Mon Mode | Off | Off, Manual, Timer, Pro-1 to Pro-8 | |
| Monday time | Auto Start Mon Time | 00:00 | 00:00 to 23:59 | |
| Tuesday mode | Auto Start Tue Mode | Off | Off, Manual, Timer, Pro-1 to Pro-8 | |
| Tuesday time | Auto Start Tue Time | 00:00 | 00:00 to 23:59 | |
| Wednesday mode | Auto Start Wed Mode | Off | Off, Manual, Timer, Pro-1 to Pro-8 | |
| Wednesday time | Auto Start Wed Time | 00:00 | 00:00 to 23:59 | |
| Thursday mode | Auto Start Thu Mode | Off | Off, Manual, Timer, Pro-1 to Pro-8 | |
| Thursday time | Auto Start Thu Time | 00:00 | 00:00 to 23:59 | |
| Friday mode | Auto Start Fri Mode | Off | Off, Manual, Timer, Pro-1 to Pro-8 | |
| Friday time | Auto Start Fri Time | 00:00 | 00:00 to 23:59 | |
| Saturday mode | Auto Start Sat Mode | Off | Off, Manual, Timer, Pro-1 to Pro-8 | |
| Saturday time | Auto Start Sat Time | 00:00 | 00:00 to 23:59 | |

PID

| Menu Item | Display | Default | Range | Setting |
|-------------------|---------------|---------|-------------------------|---------|
| Display units | PID Temp Unit | °C | °C or °F | |
| Proportional band | PID Prop Band | 6°C | 1 to 56°C (1 to 100°F) | |
| Integral reset | PID Reset | 2 | 0 to 100 seconds/repeat | |
| Derivative Rate | PID Rate | 0 | 0 to 500 seconds | |
| AutoTune | PID AutoTune | Disable | Disable, Enable | |

Control

| Menu Item | Display | Default | Range | Setting |
|----------------------|---------------------|-------------|------------------------------------|---------|
| Cycle Time | Control Cycle Time | 1 | 1 to 60 seconds | |
| High limit setpoint | Control Hi-Lim SP | Max HiLimSP | MinHiLimSP - MaxHiLimSP* | |
| High limit band | Control Hi-Lim Band | Off | Off, 3°C to 11°C (5°F to 20°F) | |
| Power fail recovery | Control PwrFRec | Stop | Stop, Restart, Hold, Resume | |
| Recovery time limit | Control PwrFTime | 00m00s | 00m00s to 99m59s | |
| Powerup start enable | Control EPwrStrt | Dis | Dis, En | |
| Powerup Start Mode | Control StrtMode | Off | Off, Manual, Timer, Pro-1 to Pro-8 | |
| Hysteresis | Control Hyst | 3°C | 1°C to 56°C (1°F to 100°F) | |
| Process out low | Control RetOutLo | 80°C | -73°C to 760°C (-100°F to 1400°F) | |
| Process out high | Control RetOutHi | 400°C | -73°C to 760°C (-100°F to 1400°F) | |
| Time scale | Control TimeScale | hh:mm | hh:mm or mm:ss | |
| Key press beep | Control KeyBeep | On | On or Off | |
| End of cycle beep | Control EOCBeep | Off | On or Off | |
| Alarm beep | Control AlarmBeep | Off | On or Off | |

*see Enable Page

Communication (optional)

| Menu Item | Display | Default | Range | Setting |
|-----------|-------------------------|---------|-----------------------------------|---------|
| Address | Communication CommAddr | 1 | 1 to 255 | |
| Mode | Communication CommMode | OFF | OFF, Modbus | |
| Baud rate | Communication Baud Rate | 19.2K | 2400, 4800, 9600, 19.2K, 38.4K | |
| Parity | Communication Parity | None | None, Odd, Even | |

Real Time Clock

| Menu Item | Display | Default | Range | Setting |
|-----------------|------------------------|---------|-----------------------------------|---------|
| Day of the week | Clock Day | Mon | Sun, Mon, Tue, Wed, Thu, Fri, Sat | |
| Time of day | Clock HH:MM | 00:00 | 00:00 to 23:59 | |
| Reset clock | Clock UP to Reset CLK* | Ready | Ready, Done | |

* if the ▲ key is not pressed, the clock values will retain their original values, the display will change to Done if the clock is reset

Relay Outputs (optional)

Push Select key to select relay. If Relay 0 appears, no relays are installed

| Menu Item | Display | Default | Range |
|--------------------|---------------------|---------|-----------------------------------|
| Type of relay | Relay 1 RelayType | Off | Off, Alarm, Cycl, Ev1 to Ev4 |
| Action of relay | Relay 1 RelayAction | NDE | NDE, NE, NDEL, NEL ***** |
| Type of alarm* | Relay 1 AlarmType | High | High, Low, Plus, Minus, Band |
| Alarm setpoint* | Relay 1 AlmHi/Lo SP | 538°C | -73°C to 760°C (-100°F to 1400°F) |
| Alarm deviation* | Relay 1 AlmDevBand | 3°C | 1 to 56°C (1 to 100°F) |
| Inhibit alarm* | Relay 1 ALMinhibit | On | En or Dis |
| Type of event** | Relay 1 EventType | Time | Time or Temp |
| Event setpoint *** | Relay 1 Event SP | SPUpLim | SPLoLim to SPUpLim**** |

(repeat for relay outputs 2-4, if available)

* appears only for alarm types

** appears only for time or temperature event types

*** appears only for temperature event types

**** see enable page

***** Normally de-energized and non-latching, normally energized and non-latching, normally de-energized and latching, normally energized and latching

Table of Settings

| Relay | Type | Action | Alarm/ Event Type | Setpoint | Alarm Deviation | Alarm Inhibit |
|-------|------|--------|----------------------|----------|--------------------|------------------|
| | | | | | | |
| | | | | | | |
| | | | | | | |
| | | | | | | |

Test

| Menu Item | Display | Default | Range | Setting |
|-------------------|---------------|------------------|-------|---------|
| Heater output | Test HeatOut | Off | On | |
| High limit relay | Test HiLimOut | Off | On | |
| Relay 1 output | Test Rly1 Out | Off | On | |
| Relay 2 output | Test Rly2 Out | Off | On | |
| Relay 3 output | Test Rly3 Out | Off | On | |
| Relay 4 output | Test Rly4 Out | Off | On | |
| High Limit Sensor | Test HL Temp | (sensor reading) | | |

Zone Cal

| Menu Item | Display | Default | Range | Setting |
|----------------------|-------------------|---------|-----------------------------------|---------|
| Zone 1 actual | Zone Cal Zone1Act | 38°C | -73°C to 760°C (-100°F to 1400°F) | |
| Zone1 displayed | Zone Cal Zone1Dis | 38°C | -73°C to 760°C (-100°F to 1400°F) | |
| Zone 2 actual | Zone Cal Zone2Act | 260°C | -73°C to 760°C (-100°F to 1400°F) | |
| Zone2 displayed | Zone Cal Zone2Dis | 260°C | -73°C to 760°C (-100°F to 1400°F) | |
| Factory calibration* | Zone Cal FactCal | Ready | Ready or Done (push- key) | |

*only use when no calibration instrument is available

Sensor Cal

| Menu Item | Display | Default | Range | Setting |
|--------------------|---|--------------------------|---|---------|
| Control Sensor Cal | Ctrl Sens 0F Ctrl Sens 1000F Ctrl Sens Done | -100°F 1400°F Done | -100 to 1400°F -100 to 1400°F (read only) | |
| HiLim Sensor Cal | HL Sens 0F HL Sens 1000F HL Sens Done | -100°F 1400°F Done | -100 to 1400°F -100 to 1400°F (read only) | |
| Retransmit Cal | RetCalLo XXXX * RetCalHi XXXX * | 0 4096 | 0 to 4096** 0 to 4096*** | |

* note that the actual RetCalLo and RetCalHi values displayed are of no importance.

** press ▲▼ keys until retransmission output = 1VDC

*** press ▲▼ keys until retransmission output = 5VDC

Enable Page

| Menu Item | Display | Default | Range | Setting |
|-----------------------------------|----------------------|---------|-----------------------------------|---------|
| Profiles | Enable Profile 1-8 | Yes | Yes or No | |
| Autostart | Enable Auto Start | No | Yes or No | |
| PID | Enable PID | Yes | Yes or No | |
| Control | Enable Control | No | Yes or No | |
| Communication | Enable Communication | No | Yes or No | |
| Real Time Clock | Enable Clock | No | Yes or No | |
| Relay outputs | Enable Relay 1-4 | No | Yes or No | |
| Test | Enable Test | No | Yes or No | |
| Zone Calibration | Enable Zone Cal | No | Yes or No | |
| Sensor Calibration | Enable Sensor Cal | No | Yes or No | |
| Setpoint lower limit | Enable SPLowerLim | 20°C | -73°C to 760°C (-100°F to 1400°F) | |
| Setpoint upper limit | Enable SPUpperLim | 260°C | -73°C to 760°C (-100°F to 1400°F) | |
| High limit overhead | Enable HiLimOH | 5°C | 3 to 11°C (5 to 20°F)* | |
| Password level 1 | Enable Password 1 | 1 | 0 to 1000 | |
| Password level 2 | Enable Password 2 | 2 | 0 to 1000 | |
| Manual/Timer mode setpoint change | Enable SPChange | Yes | Yes or No | |
| Analog Output Type | Enable Analog Type | Proc | Ctrl or Proc | |

* Maximum high limit setpoint (MaxHiLimSP) = SPUpperLim + HiLimOH
 Minimum high limit setpoint (MinHiLimSP) = SPLowerLim + HiLimOH

Technical Specifications

| | |
|----------------------------------|---|
| UL, cUL listed: | UL file E136675 |
| CE compliance to: | <ul style="list-style-type: none">• EMC Directive 89-366/EEC• European Standard EN55011/1991• European Standard EN50082-2/1995 |
| Power supply: | <ul style="list-style-type: none">• 100 to 240 VAC +10% -15%, 50-60Hz, 30VA Maximum• 12 to 24 VAC/VDC +/-10%, DC to 60Hz, 30VA Maximum |
| Temperature: | <ul style="list-style-type: none">• Storage -20 to 60°C• Operating 0 to 50°C |
| Humidity: | 90% or less, non-condensing |
| Sensor inputs: | <ul style="list-style-type: none">• Type J thermocouple -73°C to 760°C (-100°F to 1400°F)• Input impedance 1M ohm or greater• Common mode noise rejection of 140db@60Hz• Common mode input voltage of +/-12.0VDC• Sample rate of at least 1 sample per second• Stability of +/- 0.5EC per 5EC change in ambient temperature• Repeatability of +/- 0.5EC, or +/-0.1% of sensed temperature (whichever is greater)• Accuracy (@ 77°F +/-0.2 percent of span (+/-3°F)• Supply Voltage Influence of +/-0.5EC per 10% change in nominal line voltage |
| Temperature display: | <ul style="list-style-type: none">• 1 degree resolution (C or F)• Accuracy after calibration of +/- 1EC, or +/-0.2% of sensed temperature (whichever is greater) @25EC• Four-digit seven-segment LCD, 0.43 inches high (11mm)• Readout Stability (+/-1°F/10°F Change in ambient temperature) |
| Message display: | <ul style="list-style-type: none">• Two-line, 16 alpha-numeric 5x7 dot matrix characters per line• 0.2 inches high (5mm) |
| Time base: | +/- 4 seconds accuracy in 24 hours |
| Heat control output: | SSR Drive 24VDC nominal @ 70mA |
| Relay output: (plug-in module) | Form A dry contact, rated 3 amps @ 24-264VAC |
| Retransmit output: | 0 to 5 VDC into > 100K ohm load or 4-20maDC > 0-800 Ohm Load (+/-0.2% of programmed span accuracy, +/- 1LSD) |
| Communications: (plug-in module) | <ul style="list-style-type: none">• RS232 Single drop, isolated• RS422 Multi-drop, isolated• RS485 Multi-drop, isolated |
| Remote inputs: (plug-in module) | Dry-contact closure type with less than 250 ohm ON resistance |
| Front panel: | NEMA 4X (with gasket) |
| Dimensions: | 3.57H x 7.24W x 2.84D inches (91H x 184W x 72D mm) |
| Panel opening: | 3.63H x 7.30W inches (92H x 185W mm) |

Maintenance

Do not attempt any service on this oven before opening the main power disconnect switch.

WARNING:

Disconnect the main power switch or power cord before attempting any repair or adjustment.

Checklist

- Keep equipment clean. Gradual dirt accumulation retards airflow. A dirty oven can result in unsatisfactory operation such as unbalanced temperature in the work chamber, reduced heating capacity, reduced production, overheated components, etc. Keep the walls, floor and ceiling of the oven work chamber free of dirt and dust. Floating dust or accumulated dirt may produce unsatisfactory work results. Keep all equipment accessible. Do not permit other materials to be stored or piled against it.
- Protect controls against excessive heat. This is particularly true of controls, motors or other equipment containing electronic components. Temperatures greater than 51.5°C (125°F) should be avoided.
- Establish maintenance & checkup schedules. Do this promptly and follow the schedules faithfully. Careful operation and maintenance will be more than paid for in continuous, safe and economical operation.
- Maintain equipment in good repair. Make repairs immediately. Delays may be costly in added expense for labor and materials and in prolonged shut down.
- Practice safety. Make it a prime policy to know what you are doing before you do it. Make CAUTION, PATIENCE, and GOOD JUDGMENT the safety watchwords for the operation of your oven.
- Lubrication. Fan motor bearings are permanently lubricated. All door latches, hinges, door operating mechanisms, bearing or wear surfaces should be lubricated to ensure easy operation.

Inspection and Cleaning

The purpose of inspection is to determine cleanliness, proper operation and condition of the oven, including its controls indicators and moving parts.

Vents

Make sure intake and exhaust openings are clean and free of blockages. Any dirt accumulation in the air circuit can unbalance temperatures and airflow patterns.

Chamber

Keep perforated panels and other surfaces of the chamber clean. Use a vacuum cleaner to clean perforated panels.

Control Cabinet and Fan

Keep the control cabinet fan and the intake grill clean. Make sure there is a 2-inch clearance behind the oven to provide adequate ventilation.

Remove dust and cobwebs from heat sinks.

Control cabinet temperature should not exceed 52°C (125°F).

WARNING:

High voltage is present on terminals inside control cabinet. Turn off main power disconnect before cleaning inside of control cabinet. Do not use any cleaning equipment that may pull wires.

Chamber Door Gasket

Check the gasket on the chamber door as follows.

1. Open the door.
2. Visually inspect the gasket-sealing surface.
3. Squeeze the gasket between your fingers to check for damage and tears.
4. Close the door on a piece of paper at many points around the gasket. The gasket should seal tight enough to require a slight pull to remove the paper.

Recirculation Motor

Fans, motors and shaft should be clean and free of dust and oil or grease. The recirculation motor is permanently lubricated and does not require any lubrication.

Oven Exterior

Clean oven exterior with Dupont No. 7 polish or equal, or with soap and water. Do not clean while the oven is hot. Do not use abrasives or chemicals.

Oven Chamber Interior

Clean the oven interior with soap and water or stainless steel cleaner. Under normal conditions, a major cleaning should be done once a year.

Door Hinges and Latches

Check operation of the chamber door to see whether it opens easily and closes securely, without jerking or slamming.

Automatic Damper

1. Put the oven in operation (without a load in the chamber) and wait until the temperature is stabilized.
2. Set the controller to about 10°C lower.
3. While looking at the damper control motor and linkage, when the setpoint is first turned down, the dampers should move to the wide-open position.
4. Then, as the chamber temperature drops, the dampers should start to close when the difference between the chamber temperature and the setpoint is less than 4°C.
5. When the chamber temperature has dropped between 1°C and 2°C above the setpoint, the damper should be fully closed.
6. At lower chamber temperatures (compared to the setpoint), the damper remains closed and the heater is turned on.
7. Reset the temperature controller.

Controls and Indicators

Check all controls for proper operation. Switches should move easily, indicators should light or give a correct signal, and controls should perform intended function.

Loose Screws, Bolts and Fasteners

Check tightness of all screws, bolts and fasteners. Notice whether the oven vibrates or makes unusual noises while starting, running or stopping. Make sure switches and control knobs and indicators are securely fastened.

Lubrication

Fan motor bearings are permanently lubricated. All door latches, hinges, door operating mechanisms, bearing or wear surfaces should be lubricated to ensure easy operation.

Tests

Tests should be performed carefully and regularly. The safety of personnel as well as the condition of equipment may depend upon the proper operation of any one of the functions of the temperature control. Test the control every 40 hours. Check that the heater LED is cycling on and off, indicating that the heater is working. Also at this time, check the high limit function to make sure it is working properly.

To test the high limit:

1. Go to Manual Mode and enter control setpoint value at least 20°F (11° C) lower than the current process temperature.
2. Press the Menu key and lower the high limit setpoint to a value just below the current process temperature.
3. The high limit alarm indicator should flash and a high limit alarm message should be displayed. Verify that the heater relay has been disabled by checking that 2LED on the control panel circuit board is not lit.
4. Return the control setpoint and high limit setpoint values to their original values.
5. Press the Reset key.

OPTIONAL ACCESSORIES

This section provides operating instructions on the standard options for the RBC1-50 Burn-In oven.

Door Switch

The door switch is wired to shut off the fan and heater. In addition, when the N₂ and LN₂ options are installed the door switch will shut these down. The door switch may be defeated manually by pulling out the actuator.

WARNING:

Disconnect the main power switch or power cord before attempting any repair or adjustment.

WARNING:

Do not use oven in wet, corrosive or explosive atmospheres.

Recorder

The circular chart recorder, mounted on top of the oven, is used to record the user's process. This is done by an independent thermocouple, located next to the control thermocouple. The charts used are 24hr/7day. This option is available in a single pen for stand-alone units or a two pen for units using the stacking option. See the manufacturer's manual on the recorder instrument attached to this manual.

WARNING:

Failure to heed warnings in this instruction manual and on the oven could result in personal injury, property damage or death.

Redundant High-Limit

The redundant high-limit is located on the equipment panel behind the control panel door. The temperature is sensed by an independent thermocouple, located next to the control thermocouple. To operate the redundant high-limit, set the dial to the desired temperature, this is usually set at a temperature just below the safe maximum temperature of the product, but not too low to interfere with the process. If temperature of the chamber exceeds the high-limit setting on the redundant high-limit, the heater will shut down and the Alarm Horn and red pilot light will energize. The heater will shut off. To silence the alarm:

- Depress the Alarm Silence switch, this is a momentary switch, it will return to its normal position when released.
- The alarm horn will be silenced, but the red alarm pilot light will remain lit.
- When the overtemperature condition clears, press RESET on the redundant high-limit.

- The heater should be back on and the chamber should be functioning correctly.

If the high-limit trips repeatedly, verify the cause of overtemperature and correct problem. See the manufactures manual on the redundant high-limit instrument attached to this manual.

Disconnect Switch

The disconnect switch is located on the upper front of the control panel, above the controller. The OFF position is when the handle turned to the left, and ON is when it turned to the right. To access the equipment behind the control panel, the disconnect switch must be in the OFF position. This prevents access to the equipment panel while power is on the oven.

Stacking Option

When ordered, this option lets the user to stack two ovens; one on top of the other using specially designed stacking hardware. Using this option still requires that each oven have its own power supplied to it

Replacement

WARNING:

Disconnect the main power switch or power cord before attempting any repair or adjustment.

Parts

To order or return parts, contact the Service Products Division at Despatch. The Service Products Division features our Response Center for customer service. When returning parts, a Despatch representative will provide you with an MRA (Material Return Authorization) number. The MRA number must be attached to the returned part for identification. When you are ordering parts, be sure to give the model number, serial number and the part number. This will expedite the process of obtaining a replacement part.

When you have a **service** need, contact the **Response Center** at **1-800-473-7373**: FAX 612-781-5353.

Nitrogen and Liquid Nitrogen

The standard air-atmosphere oven can be converted to a nitrogen-atmosphere with a factory installable kit. The following are instructions on the operation of the nitrogen (N₂) and liquid nitrogen (LN₂) cooling option for the RBC1-50 Burn-In oven.

Theory of Operation

The nitrogen atmosphere option uses nitrogen (N₂) to displace oxygen from the chamber, thus eliminating oxidation of components. The heat is dissipated from the oven by liquid nitrogen (LN₂). Nitrogen enters the chamber and reduces the oxygen level to the desired level. The flowmeter keeps the desired N₂ entering into the chamber, maintaining a low concentration of oxygen while a burn-in cycle is in progress.

Operator Training Requirements

Users and operators of this oven must comply with operating procedures and training of operating personnel as required by the Occupational Safety and Health Act (OSHA) of 1970, Section 5 and relevant safety standards, and other safety rules and regulations of state and local governments. Refer to the relevant safety standards in OSHA and National Fire Protection Association (NFPA), Section 86 of 1990.

WARNING:

Suffocation can occur in a nitrogen atmosphere oven chamber if it is not thoroughly purged with room air before a person goes inside it. Before entering an oven chamber, run the oven for at least five minutes with the nitrogen (or any other inert) gas turned off, doors open and recirculating fan running. Only then should a person work inside the oven chamber with the doors closed.

Operation

1. Connect the nitrogen (N₂) supply line to the inlet located in the rear of the oven.
2. Set the pressure regulator to 40PSIG.
3. Connect the liquid nitrogen (LN₂) supply to the inlet located on the box in the rear of the oven.
4. Adjust the regulator to 35PSIG max.
5. Check nitrogen plumbing for leaks, using soapy water solution.
6. As gas nitrogen is odorless, all leaks should be stopped to prevent the possibility of suffocation in a small work area in which a nitrogen leak might displace much of the oxygen in the atmosphere.
7. Start chamber, and turn the Nitrogen (N₂) switch ON.
8. The pilot light on the switch indicates that the solenoid valve is open and nitrogen (N₂) is entering the chamber.
9. Adjust the flowmeter, which is located in the front control panel, and set to desired flow rate. The flow rate should set so that it creates a slightly positive pressure in the chamber, which counteracts leaks and keeps the oxygen content at a safe, low level of concentration.
10. When the oven nears temperature set on the control, the heater will start cycling on and off.

WARNING:

Do not use oven in wet, corrosive or explosive atmospheres.

CAUTION:

Nitrogen & carbon dioxide gases can cause asphyxiation if used in confined or poorly ventilated areas.

11. When the chamber temperature is above setpoint on control, the cooling output of the control will start cycling the liquid nitrogen (LN₂) solenoid valve, which will cool the chamber.

WARNING:

Failure to heed this warning can result in severe frostbite to eyes or skin. Do not touch frosted pipes or valves.

Nitrogen Atmosphere

Purge Rate

The chart below shows the time required to reduce the oxygen content to different percentages of concentration. At a flow rate of 100 SCFH in the RBC1-50 Burn-In oven, oxygen concentration from 21% in room air down to 6% in the closed oven takes approximately 11 minutes.

Flow Rate Time Versus Oxygen Content

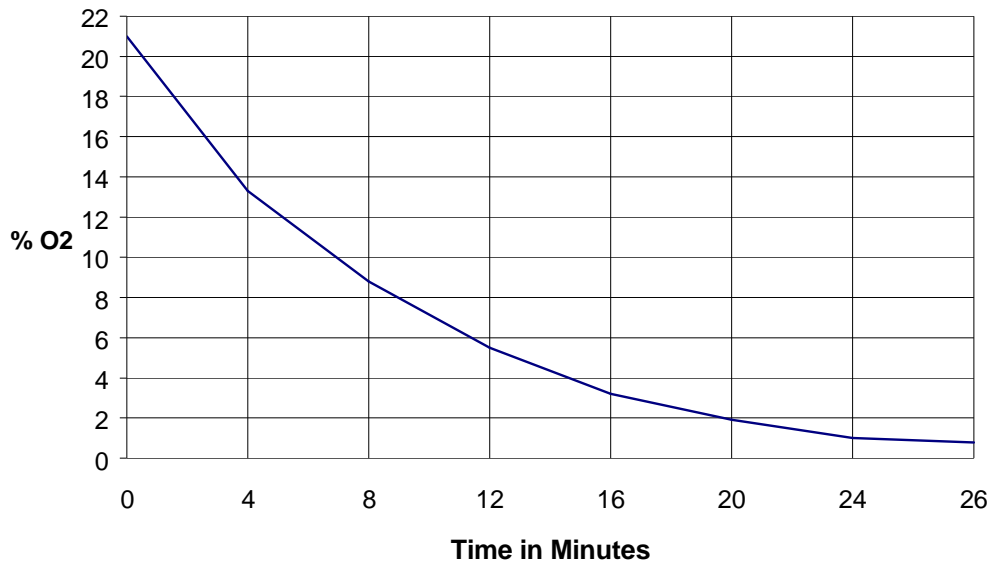

Maintain Rate

The chart below shows typical flow rate required to maintain the oxygen content at different percentages of concentration in the RBC1-50 Burn-In oven with nitrogen atmosphere option installed. For example, it requires 36SCFH to keep the oxygen concentration down to 6½ percent in the closed oven chamber. The preliminary settings can be determined from this graph. If the oxygen concentration must be determined more accurately, use an oxygen monitor.

Oxygen Stabilization vs. Flow of N2

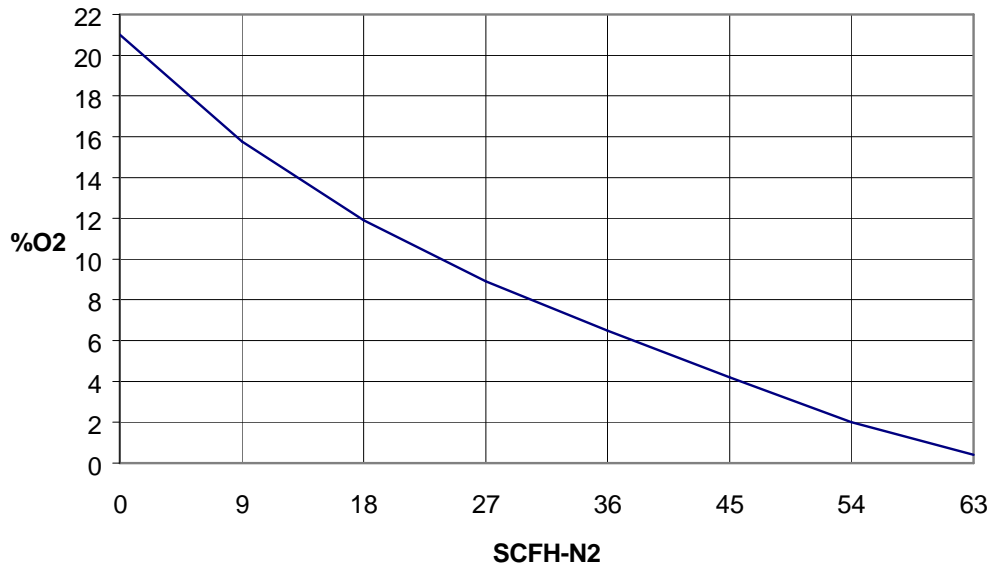

Troubleshooting

Equipment, which operates for extended lengths of time, may develop problems. Below are possible problems and suggested solutions. If you have a problem not listed and do not know what to do, contact Despatch Industries at our toll free Help Line 800-473-7373.

WARNING:
Disconnect the main power switch or power cord before attempting any repair or adjustment.

| Difficulty | Probable Cause | Suggested Remedy |
|-----------------------------------|--|--|
| Failure to heat | No power | Check power source and/or oven and wall fuses. |
| | Burned out heater | Replace heater (see warranty.) |
| | Protocol™ malfunction | Replace controller. |
| | Loose wire connections | Disconnect power and check connections behind control panel. |
| | Heater relay failure | Replace circuit board. |
| | No power to the heater | Reset High-limit(s). Make sure control is calling for heat. Check controller. Check SSR. |
| | Airflow switch open | Check airflow switch. |
| | Door switch failure (if installed) | Replace door switch. |
| Slow heat up | Improperly loaded | Reduce load or redistribute load in chamber. |
| | Low line voltage | Supply sufficient power and proper connections. Check for circuit overload. |
| | Heating element(s) are burned out | Replace heater (see warranty statement.) |
| | Fan motor failure | Replace fan motor. |
| Frequent heater element burnout | Harmful fumes generated by load | Increase vent opening or discontinue process. |
| | Spillage or splattering of material on heater elements | Disconnect power and clean oven chamber and elements. |
| | Overheating oven | Check the Hi-limit. Do not operate oven over 260°C (500°F). |
| Erratic temp. or inaccurate temp. | Protocol™ malfunction | Replace Protocol™. |
| | Improper tuning parameters | Check tuning parameters. |
| | Protocol™ miscalibration | Recalibrate Protocol™ (see section on Calibration mode.) |
| | Hi-limit setting | Hi-limit should be 10-25°C higher than setpoint. |
| | Improper offset | Check zone calibration. |

| Difficulty | Probable Cause | Suggested Remedy |
|--|--|--|
| Excess surface or door temp. | Door seal deterioration | Replace door seal. |
| Improper airflow | Fan motor failure | Replace fan motor. |
| | Fan wheel seated too low on fan shaft | Adjust fan wheel for 3/16" clearance between wheel and inlet ring. |
| | Unbalanced fan wheel | Replace fan wheel. |
| Excessive vibration | Dirty fan wheel | Clean fan. |
| | Unbalanced fan wheel | Replace fan wheel. |
| Oven will not control at setpoint | Hi-limit set too low | Set the Hi-limit higher |
| | Protocol malfunction | Replace control. |
| | SSR malfunction | Replace SSR and/or check control output voltage. |
| | Air friction of recirculation fan | Open fresh air vent. Unit will not control below minimum operating temperature with vent closed. |
| | Damper motor (exhaust) not responding | Check tuning parameters. |
| Damper motor (exhaust) not responding | Linkage binding | Observe and correct linkage. |
| | Motor not working | Check supply and signal voltage. |
| | Improper tuning parameters | Check tuning parameters. |
| Liquid nitrogen (LN ₂) not cooling | Solenoid valve not responding | Check supply voltage and control output. Replace valve. |
| | Improper tuning parameters | Check tuning parameters. |
| | Tank empty or valve is to the OFF position | Check liquid nitrogen (LN ₂) supply and valve position. |
| | Pressure regulator set too low | Adjust regulator to 35PSIG maximum. |
| Heater does not shut down until temp. reaches the Hi-limit setting | Protocol malfunction | Replace Protocol |
| | SSR malfunction | Replace SSR |
| Nitrogen (N ₂) not flowing correctly | Tank empty or valve is to the OFF position | Check nitrogen supply and valve position. |
| | Pressure regulator set too low | Adjust regulator within the acceptable range of the flowmeter. |
| | Flowmeter incorrectly set | Adjust flowmeter to the desired flow rate. |

Circuit Board Check

The circuit board mounted on the control panel has three status LED indicators to help troubleshoot if the oven is not heating.

- If LED 1 is not lit, check 2F and 3F (control fuses), or power switch.
- If LED 1 and LED 3 are lit but not LED 2, check high limit (and optional door switch, if installed).

If all three LEDs are lit, check 1F and 4F (heater relay fuses), SSR, heater, heater fuses, and heater relays.

DRAWINGS

Electrical drawings for the RBC1-50 are on the next two pages.

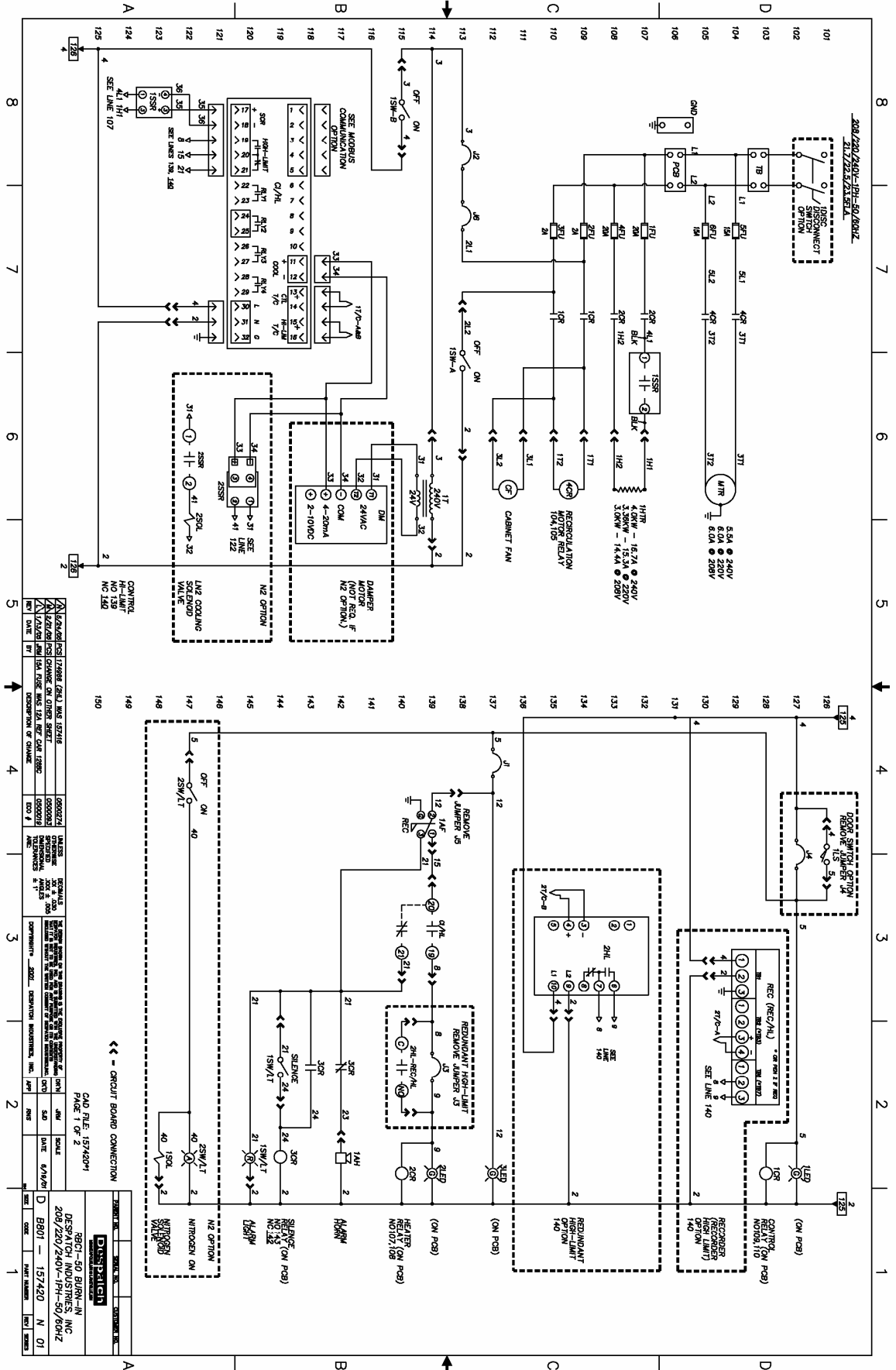

| | | | |
|----------|----------|-----|-----------------------|
| REVISION | DATE | BY | DESCRIPTION OF CHANGE |
| 1 | 08/11/20 | ... | ... |
| 2 | ... | ... | ... |
| 3 | ... | ... | ... |
| 4 | ... | ... | ... |
| 5 | ... | ... | ... |
| 6 | ... | ... | ... |
| 7 | ... | ... | ... |
| 8 | ... | ... | ... |

| | | | |
|-----|-------------|------|-----|
| NO. | DESCRIPTION | DATE | BY |
| 1 | ... | ... | ... |
| 2 | ... | ... | ... |
| 3 | ... | ... | ... |
| 4 | ... | ... | ... |
| 5 | ... | ... | ... |
| 6 | ... | ... | ... |
| 7 | ... | ... | ... |
| 8 | ... | ... | ... |

| | | | |
|-----|-------------|------|-----|
| NO. | DESCRIPTION | DATE | BY |
| 1 | ... | ... | ... |
| 2 | ... | ... | ... |
| 3 | ... | ... | ... |
| 4 | ... | ... | ... |
| 5 | ... | ... | ... |
| 6 | ... | ... | ... |
| 7 | ... | ... | ... |
| 8 | ... | ... | ... |

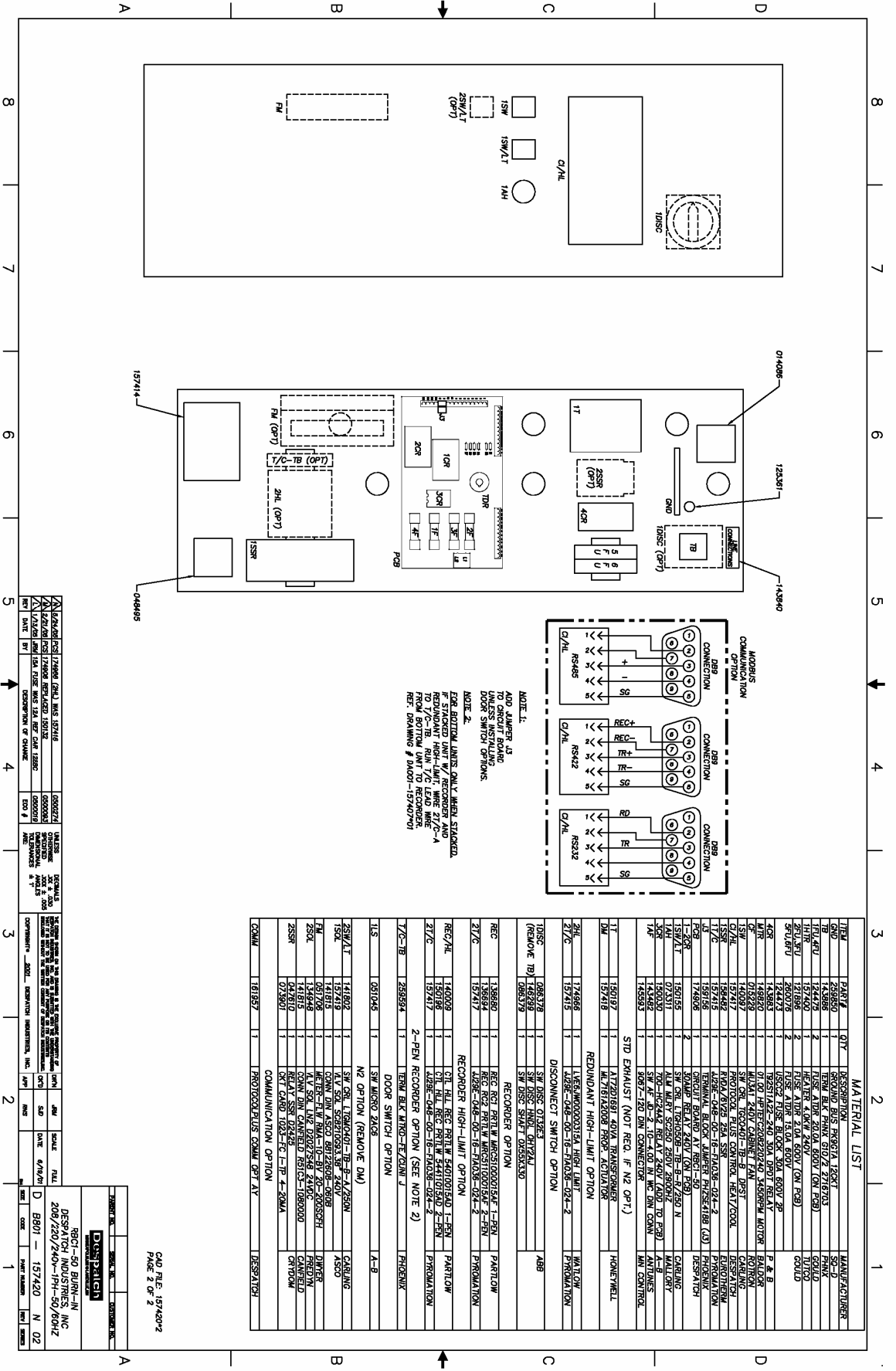

NOTE 1:
 ADD JUMPER J2
 TO CIRCUIT BOARD
 UNLESS INSTALLING
 DOOR SWITCH OPTIONS.

NOTE 2:
 FOR BOTTOM UNITS ONLY WHEN STACKED,
 THE STACKED UNIT W/ RECORDER AND
 PEN IS NOT REQUIRED. THE UNIT W/ PEN
 TO Y/C-TB RUN 7°C LEAD WIRE
 FROM BOTTOM UNIT TO RECORDER.
 REF. DRAWING # DA001-0740701

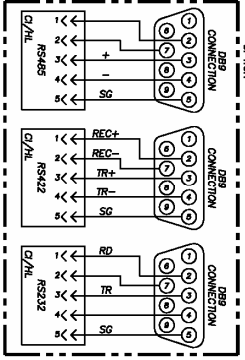

| ITEM | QTY | MATERIAL LIST | MANUFACTURER |
|--------|-----|------------------------------|--------------|
| 150197 | 1 | RECORDING | PHENIX |
| 150198 | 1 | GROUND BUS PHENIX 125X18 | PHENIX |
| 150199 | 1 | TERMINAL BLOCK 60/2 2718/203 | PHENIX |
| 150200 | 2 | RELAY ADP 20/4 60/0 (CN P20) | PHENIX |
| 150201 | 2 | RELAY ADP 20/4 60/0 (CN P20) | PHENIX |
| 150202 | 2 | RELAY ADP 20/4 60/0 (CN P20) | PHENIX |
| 150203 | 2 | RELAY ADP 20/4 60/0 (CN P20) | PHENIX |
| 150204 | 2 | RELAY ADP 20/4 60/0 (CN P20) | PHENIX |
| 150205 | 2 | RELAY ADP 20/4 60/0 (CN P20) | PHENIX |
| 150206 | 2 | RELAY ADP 20/4 60/0 (CN P20) | PHENIX |
| 150207 | 2 | RELAY ADP 20/4 60/0 (CN P20) | PHENIX |
| 150208 | 2 | RELAY ADP 20/4 60/0 (CN P20) | PHENIX |
| 150209 | 2 | RELAY ADP 20/4 60/0 (CN P20) | PHENIX |
| 150210 | 2 | RELAY ADP 20/4 60/0 (CN P20) | PHENIX |
| 150211 | 2 | RELAY ADP 20/4 60/0 (CN P20) | PHENIX |
| 150212 | 2 | RELAY ADP 20/4 60/0 (CN P20) | PHENIX |
| 150213 | 2 | RELAY ADP 20/4 60/0 (CN P20) | PHENIX |
| 150214 | 2 | RELAY ADP 20/4 60/0 (CN P20) | PHENIX |
| 150215 | 2 | RELAY ADP 20/4 60/0 (CN P20) | PHENIX |
| 150216 | 2 | RELAY ADP 20/4 60/0 (CN P20) | PHENIX |
| 150217 | 2 | RELAY ADP 20/4 60/0 (CN P20) | PHENIX |
| 150218 | 2 | RELAY ADP 20/4 60/0 (CN P20) | PHENIX |
| 150219 | 2 | RELAY ADP 20/4 60/0 (CN P20) | PHENIX |
| 150220 | 2 | RELAY ADP 20/4 60/0 (CN P20) | PHENIX |
| 150221 | 2 | RELAY ADP 20/4 60/0 (CN P20) | PHENIX |
| 150222 | 2 | RELAY ADP 20/4 60/0 (CN P20) | PHENIX |
| 150223 | 2 | RELAY ADP 20/4 60/0 (CN P20) | PHENIX |
| 150224 | 2 | RELAY ADP 20/4 60/0 (CN P20) | PHENIX |
| 150225 | 2 | RELAY ADP 20/4 60/0 (CN P20) | PHENIX |
| 150226 | 2 | RELAY ADP 20/4 60/0 (CN P20) | PHENIX |
| 150227 | 2 | RELAY ADP 20/4 60/0 (CN P20) | PHENIX |
| 150228 | 2 | RELAY ADP 20/4 60/0 (CN P20) | PHENIX |
| 150229 | 2 | RELAY ADP 20/4 60/0 (CN P20) | PHENIX |
| 150230 | 2 | RELAY ADP 20/4 60/0 (CN P20) | PHENIX |
| 150231 | 2 | RELAY ADP 20/4 60/0 (CN P20) | PHENIX |
| 150232 | 2 | RELAY ADP 20/4 60/0 (CN P20) | PHENIX |
| 150233 | 2 | RELAY ADP 20/4 60/0 (CN P20) | PHENIX |
| 150234 | 2 | RELAY ADP 20/4 60/0 (CN P20) | PHENIX |
| 150235 | 2 | RELAY ADP 20/4 60/0 (CN P20) | PHENIX |
| 150236 | 2 | RELAY ADP 20/4 60/0 (CN P20) | PHENIX |
| 150237 | 2 | RELAY ADP 20/4 60/0 (CN P20) | PHENIX |
| 150238 | 2 | RELAY ADP 20/4 60/0 (CN P20) | PHENIX |
| 150239 | 2 | RELAY ADP 20/4 60/0 (CN P20) | PHENIX |
| 150240 | 2 | RELAY ADP 20/4 60/0 (CN P20) | PHENIX |
| 150241 | 2 | RELAY ADP 20/4 60/0 (CN P20) | PHENIX |
| 150242 | 2 | RELAY ADP 20/4 60/0 (CN P20) | PHENIX |
| 150243 | 2 | RELAY ADP 20/4 60/0 (CN P20) | PHENIX |
| 150244 | 2 | RELAY ADP 20/4 60/0 (CN P20) | PHENIX |
| 150245 | 2 | RELAY ADP 20/4 60/0 (CN P20) | PHENIX |
| 150246 | 2 | RELAY ADP 20/4 60/0 (CN P20) | PHENIX |
| 150247 | 2 | RELAY ADP 20/4 60/0 (CN P20) | PHENIX |
| 150248 | 2 | RELAY ADP 20/4 60/0 (CN P20) | PHENIX |
| 150249 | 2 | RELAY ADP 20/4 60/0 (CN P20) | PHENIX |
| 150250 | 2 | RELAY ADP 20/4 60/0 (CN P20) | PHENIX |
| 150251 | 2 | RELAY ADP 20/4 60/0 (CN P20) | PHENIX |
| 150252 | 2 | RELAY ADP 20/4 60/0 (CN P20) | PHENIX |
| 150253 | 2 | RELAY ADP 20/4 60/0 (CN P20) | PHENIX |
| 150254 | 2 | RELAY ADP 20/4 60/0 (CN P20) | PHENIX |
| 150255 | 2 | RELAY ADP 20/4 60/0 (CN P20) | PHENIX |
| 150256 | 2 | RELAY ADP 20/4 60/0 (CN P20) | PHENIX |
| 150257 | 2 | RELAY ADP 20/4 60/0 (CN P20) | PHENIX |
| 150258 | 2 | RELAY ADP 20/4 60/0 (CN P20) | PHENIX |
| 150259 | 2 | RELAY ADP 20/4 60/0 (CN P20) | PHENIX |
| 150260 | 2 | RELAY ADP 20/4 60/0 (CN P20) | PHENIX |
| 150261 | 2 | RELAY ADP 20/4 60/0 (CN P20) | PHENIX |
| 150262 | 2 | RELAY ADP 20/4 60/0 (CN P20) | PHENIX |
| 150263 | 2 | RELAY ADP 20/4 60/0 (CN P20) | PHENIX |
| 150264 | 2 | RELAY ADP 20/4 60/0 (CN P20) | PHENIX |
| 150265 | 2 | RELAY ADP 20/4 60/0 (CN P20) | PHENIX |
| 150266 | 2 | RELAY ADP 20/4 60/0 (CN P20) | PHENIX |
| 150267 | 2 | RELAY ADP 20/4 60/0 (CN P20) | PHENIX |
| 150268 | 2 | RELAY ADP 20/4 60/0 (CN P20) | PHENIX |
| 150269 | 2 | RELAY ADP 20/4 60/0 (CN P20) | PHENIX |
| 150270 | 2 | RELAY ADP 20/4 60/0 (CN P20) | PHENIX |
| 150271 | 2 | RELAY ADP 20/4 60/0 (CN P20) | PHENIX |
| 150272 | 2 | RELAY ADP 20/4 60/0 (CN P20) | PHENIX |
| 150273 | 2 | RELAY ADP 20/4 60/0 (CN P20) | PHENIX |
| 150274 | 2 | RELAY ADP 20/4 60/0 (CN P20) | PHENIX |
| 150275 | 2 | RELAY ADP 20/4 60/0 (CN P20) | PHENIX |
| 150276 | 2 | RELAY ADP 20/4 60/0 (CN P20) | PHENIX |
| 150277 | 2 | RELAY ADP 20/4 60/0 (CN P20) | PHENIX |
| 150278 | 2 | RELAY ADP 20/4 60/0 (CN P20) | PHENIX |
| 150279 | 2 | RELAY ADP 20/4 60/0 (CN P20) | PHENIX |
| 150280 | 2 | RELAY ADP 20/4 60/0 (CN P20) | PHENIX |
| 150281 | 2 | RELAY ADP 20/4 60/0 (CN P20) | PHENIX |
| 150282 | 2 | RELAY ADP 20/4 60/0 (CN P20) | PHENIX |
| 150283 | 2 | RELAY ADP 20/4 60/0 (CN P20) | PHENIX |
| 150284 | 2 | RELAY ADP 20/4 60/0 (CN P20) | PHENIX |
| 150285 | 2 | RELAY ADP 20/4 60/0 (CN P20) | PHENIX |
| 150286 | 2 | RELAY ADP 20/4 60/0 (CN P20) | PHENIX |
| 150287 | 2 | RELAY ADP 20/4 60/0 (CN P20) | PHENIX |
| 150288 | 2 | RELAY ADP 20/4 60/0 (CN P20) | PHENIX |
| 150289 | 2 | RELAY ADP 20/4 60/0 (CN P20) | PHENIX |
| 150290 | 2 | RELAY ADP 20/4 60/0 (CN P20) | PHENIX |
| 150291 | 2 | RELAY ADP 20/4 60/0 (CN P20) | PHENIX |
| 150292 | 2 | RELAY ADP 20/4 60/0 (CN P20) | PHENIX |
| 150293 | 2 | RELAY ADP 20/4 60/0 (CN P20) | PHENIX |
| 150294 | 2 | RELAY ADP 20/4 60/0 (CN P20) | PHENIX |
| 150295 | 2 | RELAY ADP 20/4 60/0 (CN P20) | PHENIX |
| 150296 | 2 | RELAY ADP 20/4 60/0 (CN P20) | PHENIX |
| 150297 | 2 | RELAY ADP 20/4 60/0 (CN P20) | PHENIX |
| 150298 | 2 | RELAY ADP 20/4 60/0 (CN P20) | PHENIX |
| 150299 | 2 | RELAY ADP 20/4 60/0 (CN P20) | PHENIX |
| 150300 | 2 | RELAY ADP 20/4 60/0 (CN P20) | PHENIX |

DATE: 2/20/2007 10:50 AM
 DRAWN BY: D. B. B. / 157420 N 02
 CHECKED BY: D. B. B. / 157420 N 02
 APPROVED BY: D. B. B. / 157420 N 02

APPENDIX: Temperature Scale Conversion and Optional MRC5000 Setup

Temperature Scale Conversion (C/F)

The Protocol Plus controller can be operated in either C or F. The default setting for the controller is C. Changing from one to the other is as follows:

1. Go into the **Setup Mode** on the controller.
2. Press the **Select** Key until **Setup** is displayed.
3. Press the **Page** key and **Security** will be displayed.
4. Press the **Menu** Key and **Password** will be displayed. Use the **arrow** keys to enter the proper password. The default password is 2 for level two.
5. Once the proper password is displayed, press the **Page** key until **PID** is displayed.
6. Press the **Menu** key and **Temp Unit** along with C or F will be displayed. Use the arrow keys to change the setting.
7. Once the proper setting is displayed, press and hold the **Page** key for approximately three seconds to exit the **Setup Mode**.

Optional MRC5000 Recorder Setup

The temperature is retransmitted to the Recorder from the Controller. Set up the Recorder as follows:

1. Make sure that jumper **JU1** is setup for the **5 VDC** setting (see MRC Manual).
2. Move the **Mode** switch to the **PROG/TEST/CAL** position, and **Prog** will be displayed.
3. Press the **down arrow** key twice and **Inps** will be displayed. Make sure the settings are per the table below.
4. Once all the settings have been changed, move the **Mode** switch to the **RUN** position. The display on both the Recorder and controller should read the same.

| Parameter Code | Degrees C | Degrees F |
|----------------|-----------|-----------|
| Inps | 18 | 18 |
| Icor | 0 | 0 |
| diSP | On | On |
| dPOS | 0 | 0 |
| EUU ** | 400 | 752 |
| EUL ** | 0 | 32 |
| ChUP | 400 | 800 * |
| ChLO | 0 | 0 |
| DFF | 1 | 1 |

* Note: The 0 - 400 chart paper must be changed to the 0 - 800 chart paper. Depending on the equipment, 0 - 600 paper can be used if the maximum temperature is 500 degrees F.

** Note: These values must match the setting sRetOutLo and RetOutHi on the Control page on the Protocol Plus controller (example: RetOutLo is 32, then EUL must read 32).